



Series
NSX

ENVIRONMENTAL SIZE 8 CRIMP TRIAX PIN CONTACT
FOR RGX179 TRIAX CABLE

Issue:
02 DEC. 2005

Page
1/1

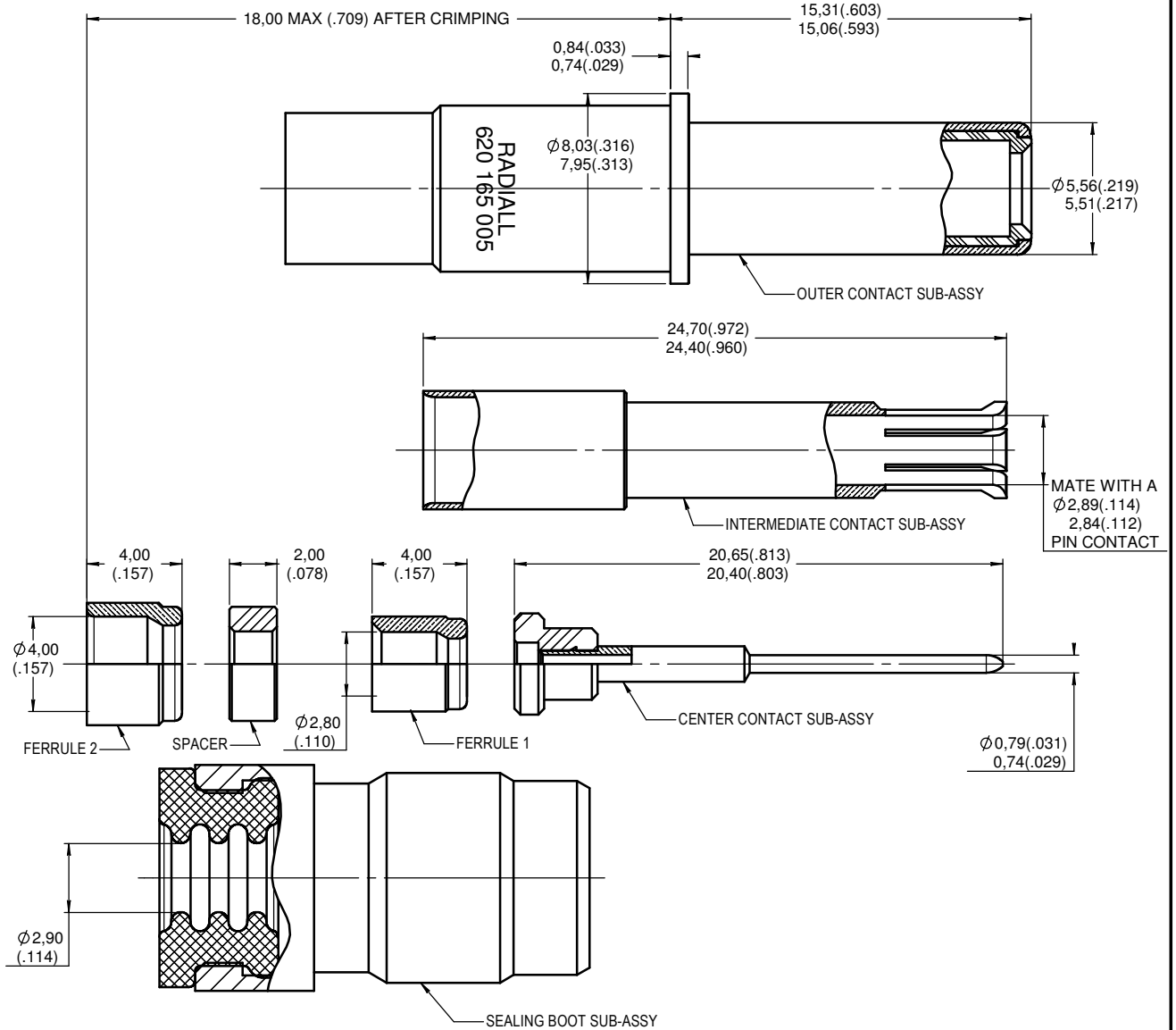

MATERIAL:
 OUTER CONTACT: BRASS PER QQ-B-626
 INTERMEDIATE CONTACT: BERYLLIUM COPPER PER ASTM-B-196
 CENTER CONTACT: LEADED NICKEL COPPER (C97)
 FERRULES: BRASS PER QQ-B-626
 DIELECTRIC AND SPACER: TPFE PER ASTM-D-1710 OR EQUIVALENT
 SEALING BOOT: THERMOPLASTIC PER MIL-P-46184 AND FLUOROSILICONE PER MIL-R-25988 OR ZZ-R-765

FINISH:
 CONTACTS AND FERRULES: GOLD PER MIL-G-45204 TYPE I OR II, GRADE C OR D, CLASS 1 OVER NICKEL PER QQ-N-290

TOOLING:
 WIRING INSTRUCTION SEE RP57028
 CENTER CONTACT: CRIMPING TOOL M22520/2.01
 POSITIONER RADIAL 282 581 011
 INTERMEDIATE AND OUTER CONTACTS: CRIMPING TOOL M22520/5.01
 DIE M22520/5.05
 EXTRACTION TOOL: M81969/28-03

DIMENSIONS : mm (inch) -

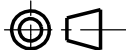

This information is given as an indication in the continual goal to improve our products, we reserve the right to make any modifications judged necessary.

4112_9311

CREATION PEN: M040732024B NOM: MACARI DATE: 16 DEC.04 APPR.: MONDOT				
	02/12/05	REMOVE PRELIMINARY	GOMBERT	MACARI
	Issue	Revisions	Name	Approved