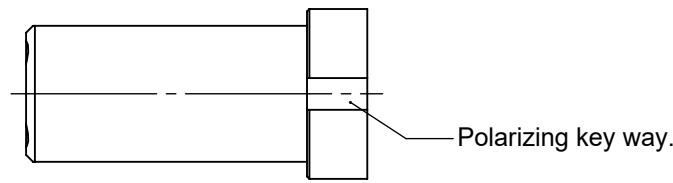
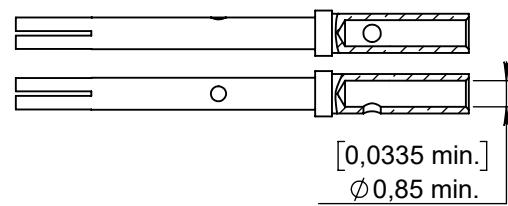
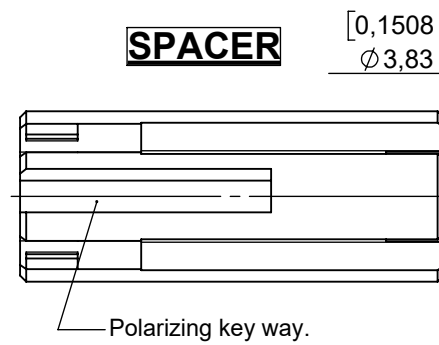
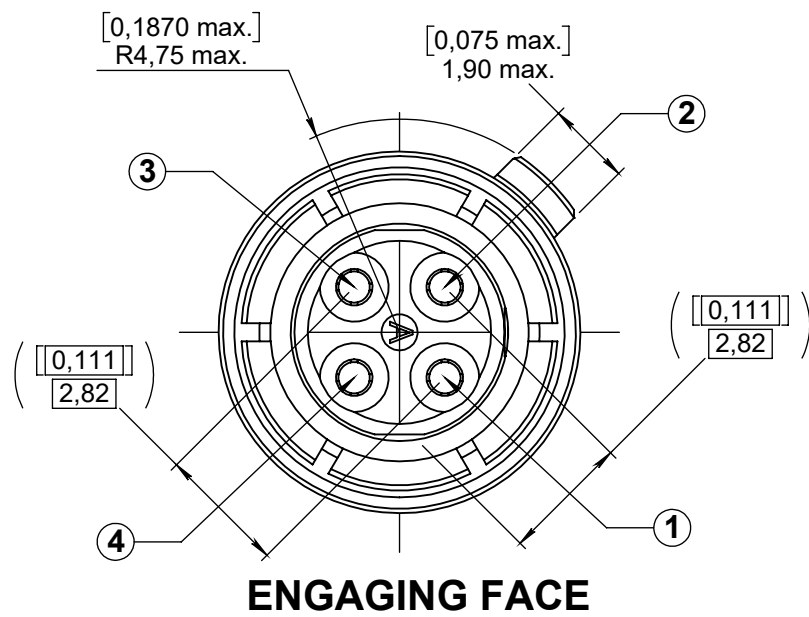
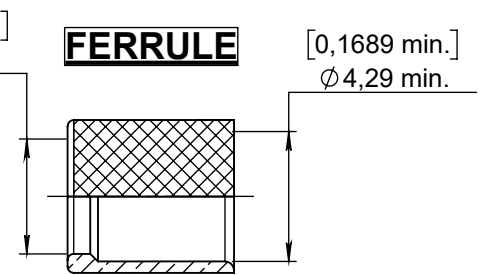

**Series  
NSX**
**NONENVIRONMENTAL SIZE 8 QUADRAX SOCKET CONTACT  
FOR QUADRAX TENSOLITE NF24Q100 (BMS13-72T03C04G024), ECS 422404  
PICE51424 AND THERMAX MX100Q24 CABLES**
**Issue:  
May 19, 2025**
**Page  
1/1**
**DESIGNED PER ARINC 600**
**OUTER CONTACT**

**INSULATOR**

**CENTER CONTACTS**

**SPACER**

**FERRULE**

**ENGAGING FACE**
**MATERIAL :**

- Outer contact, center contacts and ferrule : copper alloy
- Insulator : PTFE or suitable material
- Spacer : thermoplastic or suitable material

**FINISH :**

- Outer contact : 0,80 $\mu$ m (.000031") mini of gold over nickel
- Center contacts : 1,27 $\mu$ m (.000050") mini of gold over nickel
- Ferrule : 0,50 $\mu$ m (.000020") mini of gold over nickel

**EXTRACTION TOOL :**

- Metallic tool : M81969/28-03 (RADIALL : 282549001)
- Plastic tool : M81969/14-06

**WIRING INSTRUCTIONS :**

- RP57339

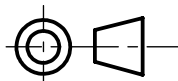
**DIMENSIONS : mm (inch are given for information only)**

Estimated weight : 4,20g

**CREATION**

PEN: 24012941-10A

NOM: Legeay H.

DATE: May 19, 2025

APPR.: Legendre T.

Issue	Revisions	Name	Approved

620075078EN

RADIALL PROPRIETARY INFORMATION

This document contains proprietary information and such information shall not be disclosed to any third party for any purpose whatsoever or used for manufacturing purposes without prior written agreement from RADIALL. This information is given as an indication. In the continual goal to improve our products, we reserve the right to make any modifications judged necessary.

4112\_9311