

Series
NSX

SIZE 10 CRIMP SOCKET TRIAX CONTACT
ABS1682 F 10 A
FOR EN3375-006 AND ASNE0290XM24 CABLES

Issue:
Oct. 13, 2011

Page
1/1

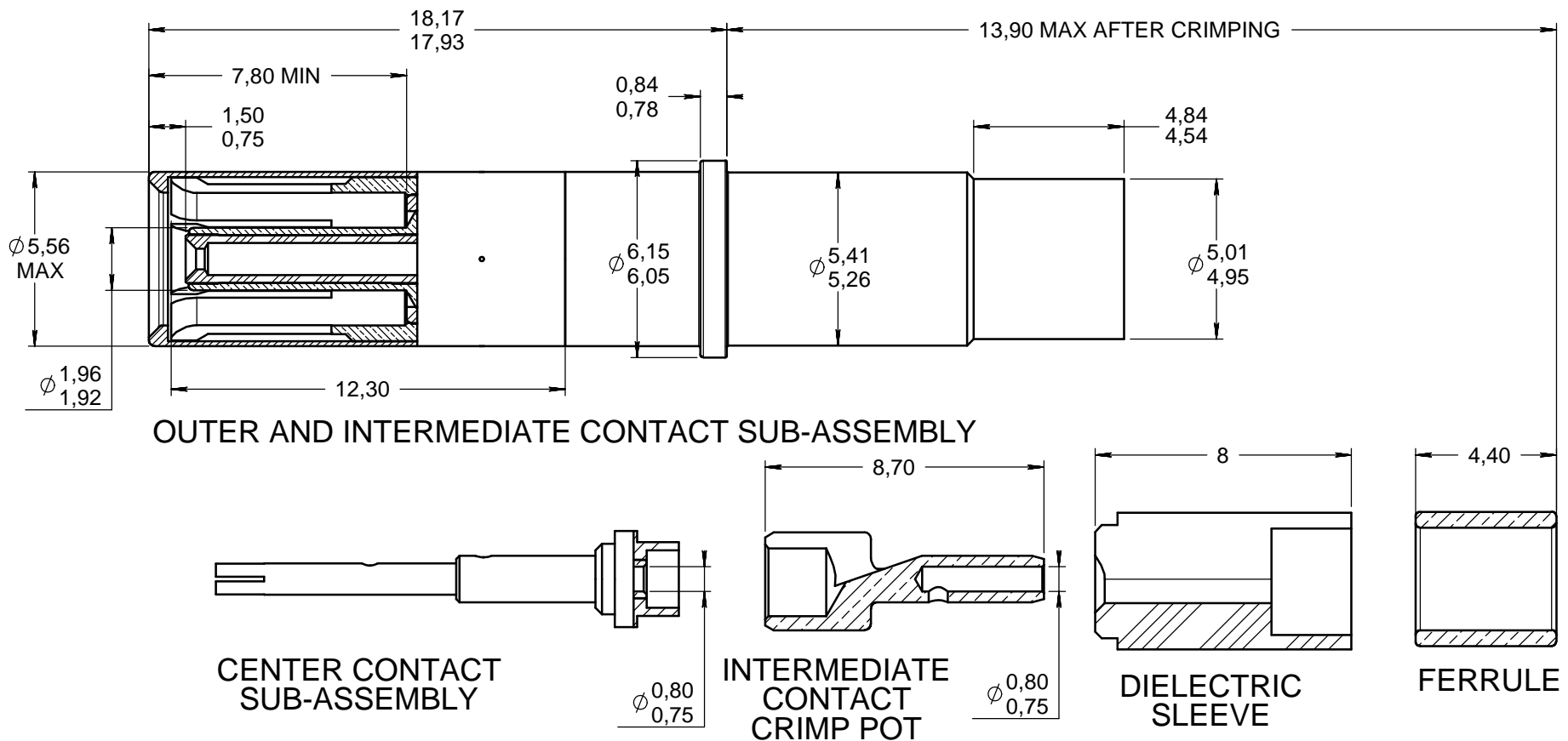

MATERIAL:

- OUTER, INTERMEDIATE AND CENTER CONTACT: BERYLLIUM COPPER PER ASTM B 196
- INTERMEDIATE CRIMP POT : LEADED NICKEL COPPER (C97)
- FERRULE : BRASS PER ASTM B 16 OR ASTM B 453 OR EN 12164
- PROTECTIVE SLEEVE : STAINLESS STEEL PER SAE AMS-5514
- DIELECTRIC : PTFE PER ASTM D 1710 OR EQUIVALENT

FINISH:

- ALL METAL PARTS: .00005 INCH GOLD PER SAE AMS-2422 OVER NICKEL PER SAE AMS-QQ-N-290
- CONTACT PROTECTIVE SLEEVE : PASSIVATED

TOOLING AND WIRING INSTRUCTIONS SEE MICT02 00003

EXTRACTION TOOL: M81969/14-05

DIMENSIONS : mm (inch are given for information only)

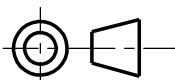

This information is given as an indication. In the continual goal to improve our products, we reserve the right to make any modifications judged necessary.

4112_9311

CREATION PEN: M080004015A NOM: MACARI DATE: April 07, 2008 APPR.: LEGENDRE	Oct. 13, 11	Added dimension of crimp area	Legendre	Dupuis
	Aug. 27, 10	Deleted "PRELIMINARY" + 13,80 max => 13,90 max	Legendre	Brochet
	June 22, 10	Reduction of the insertion force	Mary	Brochet
	Oct 02, 09	Delette "Qualification in progress"	Macari	Legendre
	Mar. 16, 09	Added Preliminary & Qualification in progress	Macari	Legendre
	Dec. 12, 08	Added wiring instructions MICT02 00003	Macari	Legendre
	Dec. 08, 08	Added .00005 inch of gold	Macari	Legendre
	Issue	Revisions	Name	Approved