



Series
MPX

SIZE 16 COAXIAL SOCKET CONTACT FOR CABLES: KX2, RG 178 AND ASNE 0633

Issue:
11 JAN.99

Page
1 / 1

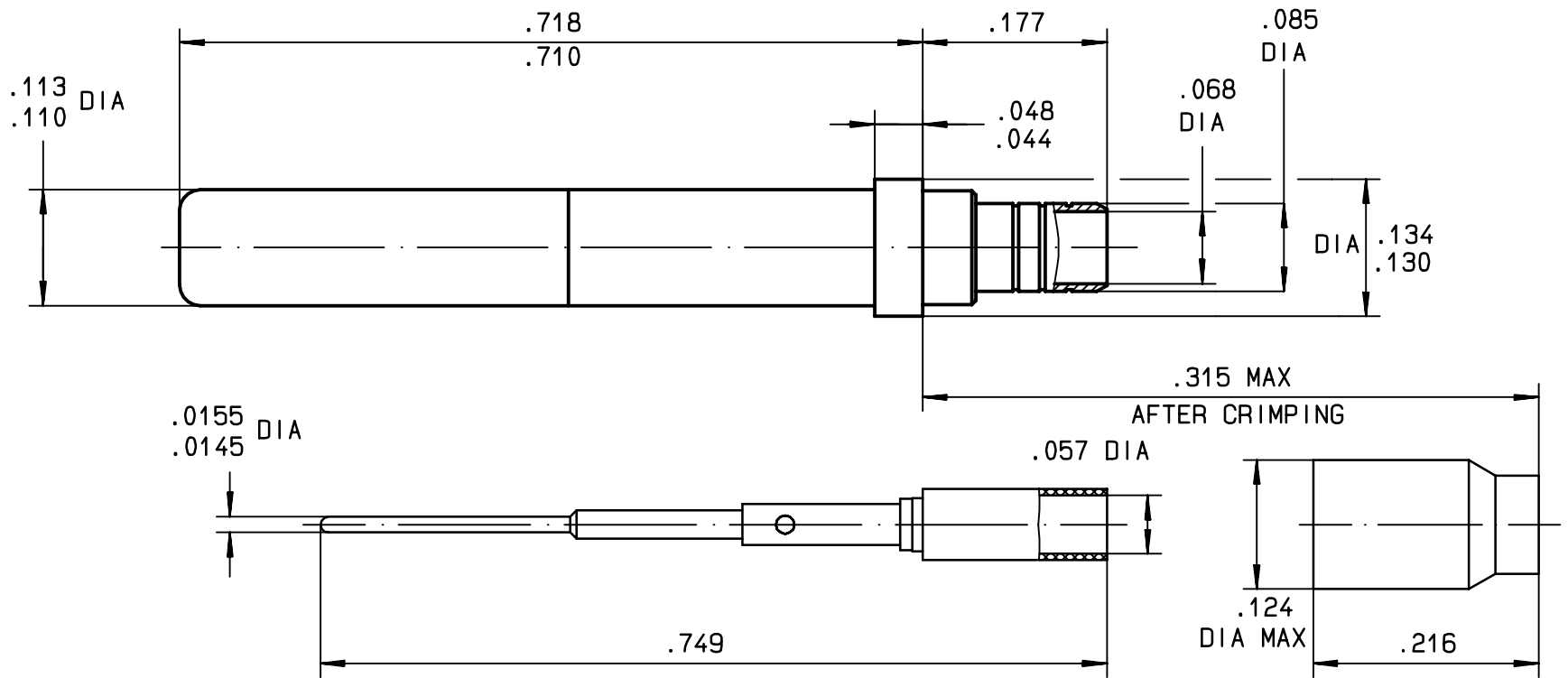

WIRING INSTRUCTIONS

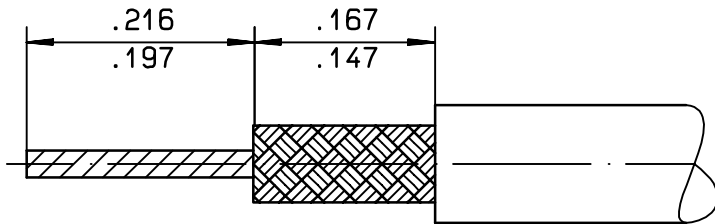

1-STRIP THE CABLE AS SHOWN

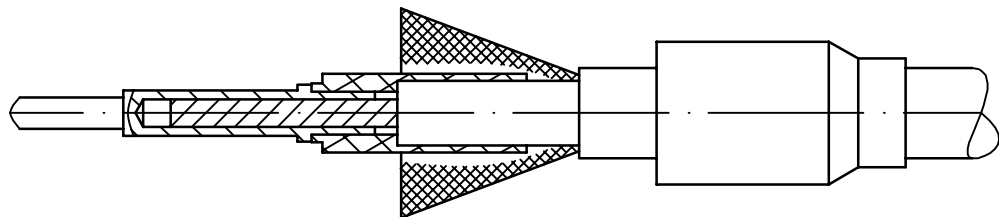

2-SLIDE FERRULE OVER SHEATH
FLARE THE BRAID
INSERT CENTER CONDUCTOR TO CENTER CONTACT
CRIMP CENTER CONTACT USING TOOL:
CRIMPING TOOL M22520/2.01 (RADIALL 282281)
SELECTOR SET 1 FOR ASNE 0633
SELECTOR SET 2 FOR RG 178 AND KX 21
POSITIONER DANIELS K370 (RADIALL 282555)

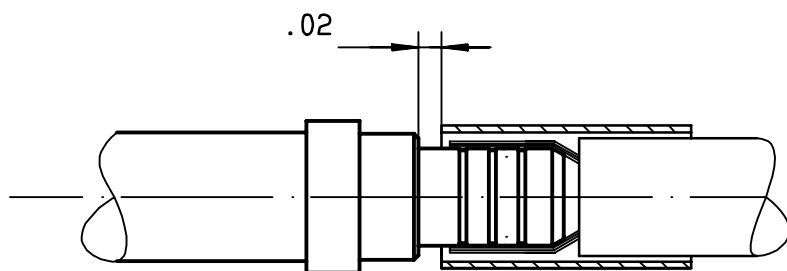

3-PUSH CABLE ASSEMBLY INTO BODY CONTACT
FOLD BRAID OVER BARREL
SLIDE FERRULE TO .02 OF SHOULDER BARREL
CRIMP THE FERRULE, TURN THE CONTACT OF ABOUT 45°
AND CRIMP THE FERRULE A SECOND TIME USING TOOL
CRIMPING TOOL M22520/4.01 (RADIALL 282292)
POSITIONER RADIALL 282556

REMOVABLE TOOL RADIALL 282892

This information is given as an indication. In the continual goal to improve our products, we reserve the right to make any modifications judged necessary.

4112_9311

CREATION				
PEN: M93012003A				
NOM: BALDYROU				
DATE: 2 OCT.95				
APPR.: VALGRESY	11 JAN.99	ADDED ASNE 0633 CABLE (FET 2975)	MACARI	
	Issue	Revisions	Name	Approved