

Series
DSX

SIZE 22 CRIMP RECEPTACLE CONTACT
WIRE SIZE AWG 22-24-26
COMPLIANT TO M39029/12-148

Issue:
Nov. 07, 2014

Page
1/1

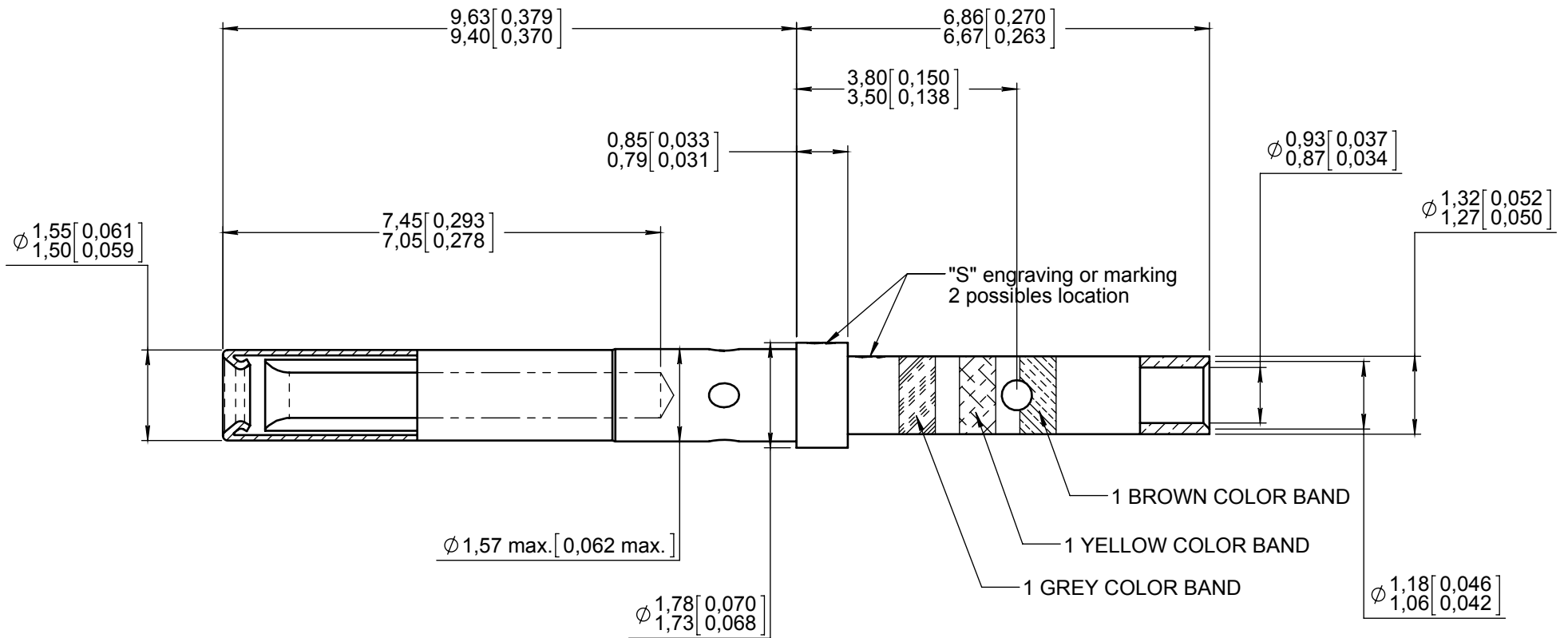
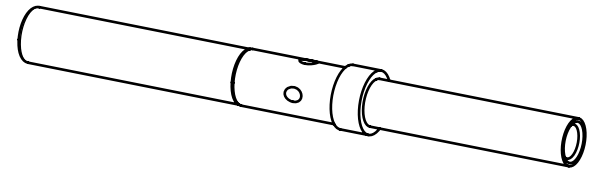

MATERIAL :

- BODY CONTACT : LEAD NICKEL COPPER
- PROTECTIVE SLEEVE : PASSIVATED STAINLESS STEEL AISI 305

FINISH :

- BODY CONTACT : GOLD PER MIL-G-45204 TYPE I OR II GRADE C OR D CLASS 1 50 MICROINCHES OVER NICKEL PLATE PER QQ-N-290

WIRES ACCOMODATED : AWG 22-24-26
INSULATOR DIAMETER : .054 MAX (1,40)
STRIP LENGHT : .138 (3,50)

CRIMP CONTACT TENSILE REQUIREMENTS USING MIL SPEC TOOLING AND WIRE SPEC
M22520/2-01 22 GA. 11 LBS (5,5 daN)

CRIMPED CONTACTS WILL SHOW NO CRACK WHEN INSPECTED PER MIL-C-22520 AT 10X

RADIALL TOOLING RECOMMENDATION

CRIMPING TOOL : M22520/2-01 (RADIALL 282 281)

SELECTOR POSITION : 4 FOR AWG 22

3 FOR AWG 24

3 FOR AWG 26

POSITIONER : M22520/2-23 (RADIALL 282 970)

INSERTION/EXTRACTION TOOL : M81969/1-01 (RADIALL 282 885) OR M81969/14-01 (RADIALL 282522)
SPL RADIALL INS. 282 880 / EXT. 282 890

DIMENSIONS : mm (inch are given for information only)

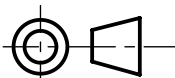

Estimated weight : 0.15 g

CREATION				
PEN: /				
NOM: FALETTI	NOV. 07, 2014	Added M81969/14-01 (RADIALL 282522)	Zuniga	Dupuis
DATE: May 29, 1988	DEC. 02, 2003	Add M39029/12-148 in the title	Moutault	Dupuis
APPR.: /	JUN. 29, 1998	Drawing english creating	Fischer	Gombert
	Issue	Revisions	Name	Approved

616300EN

RADIALL PROPRIETARY INFORMATION

This document contains proprietary information and such information shall not be disclosed to any third party for any purpose whatsoever or used for manufacturing purposes without prior written agreement from RADIALL. This information is given as an indication. In the continual goal to improve our products, we reserve the right to make any modifications judged necessary.

4112_9311