



Series  
DSX

SIZE 9 CONCENTRIC TWINAX SOCKET CONTACT FOR ENVIRONMENTAL INSERT C8 AND T8 ONLY  
FOR PAN6421 CABLE

Issue: 1 / 1  
AUGUST 01, 2003

OUTER AND INTERMEDIATE CONTACT SUB-ASSEMBLY

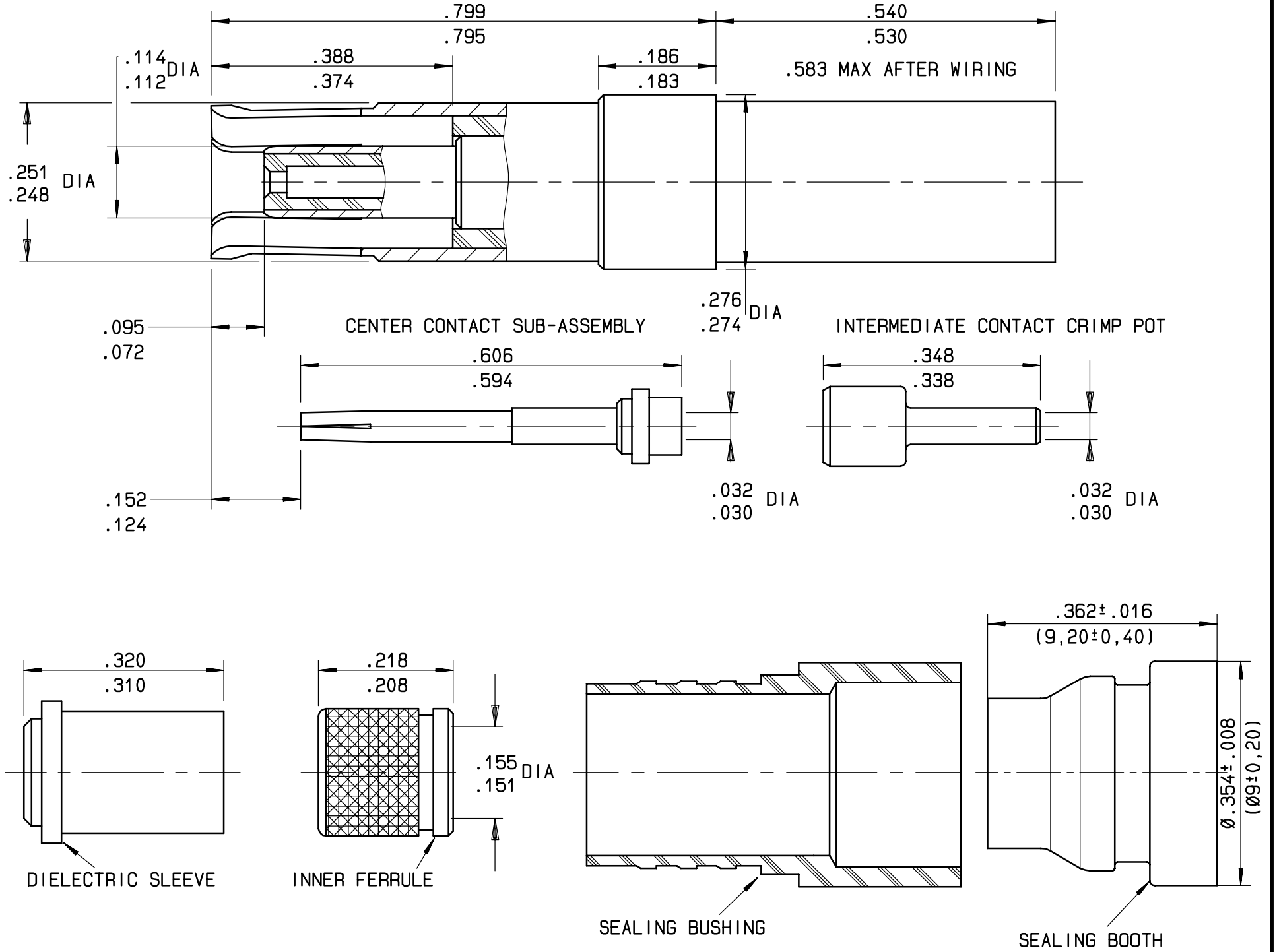

MATERIAL AND FINISH

ALL METAL PARTS: COPPER ALLOY\_GOLD OVER NICKEL  
DIELECTRIC PARTS: TEFLON

TOOLS

CENTER CONTACT: CRIMPING TOOL M22520/2\_01 (RADIALL P/N 282281)  
SELECTOR SET: 5  
POSITIONER: RADIALL P/N 282576  
INTERMEDIATE CONTACT CRIMP POT: CRIMPING TOOL M22520/2\_01 (RADIALL P/N 282281)  
SELECTOR SET: 5  
POSITIONER: RADIALL P/N 282574  
OUTER CONTACT: CRIMPING TOOL M22520/5\_01 (RADIALL P/N 282293)  
DIE M22520/5\_45 (RADIALL P/N 282236) DIE CLOSURE B .216/FLATS

EXTRACTION TOOL M81969/28\_01 (RADIALL 282946)

EXTRACTION AND INSERTION TOOL FOR SEALING BUSHING P/N (RADIALL 282549015)

WIRING SEE SPECIFICATION RP3364

ATTENTION : SLIDE OUTER SEALING BOOTH AND SEALING BUSHING OVER THE CABLE BEFORE WIRING

This information is given as an indication. In the continual goal to improve our products, we reserve the right to make any modifications judged necessary.

4112-9610

CREATION				
PEN: M030104820A				
NOM: B.GOMBERT				
DATE: 01 AUGUST 03				
APPR.: C.LAHOREAU	Issue	Revisions	Name	Approved