



RADIALL[®]
MULTICONTACT CONNECTORS

TECHNICAL DATA SHEET

610108

Series
DSX

SIZE 1 COAXIAL SOCKET CONTACT
FOR RG214, RG225, KX24 and RG393B/U

Issue:
26/10/00

Page
1 / 2

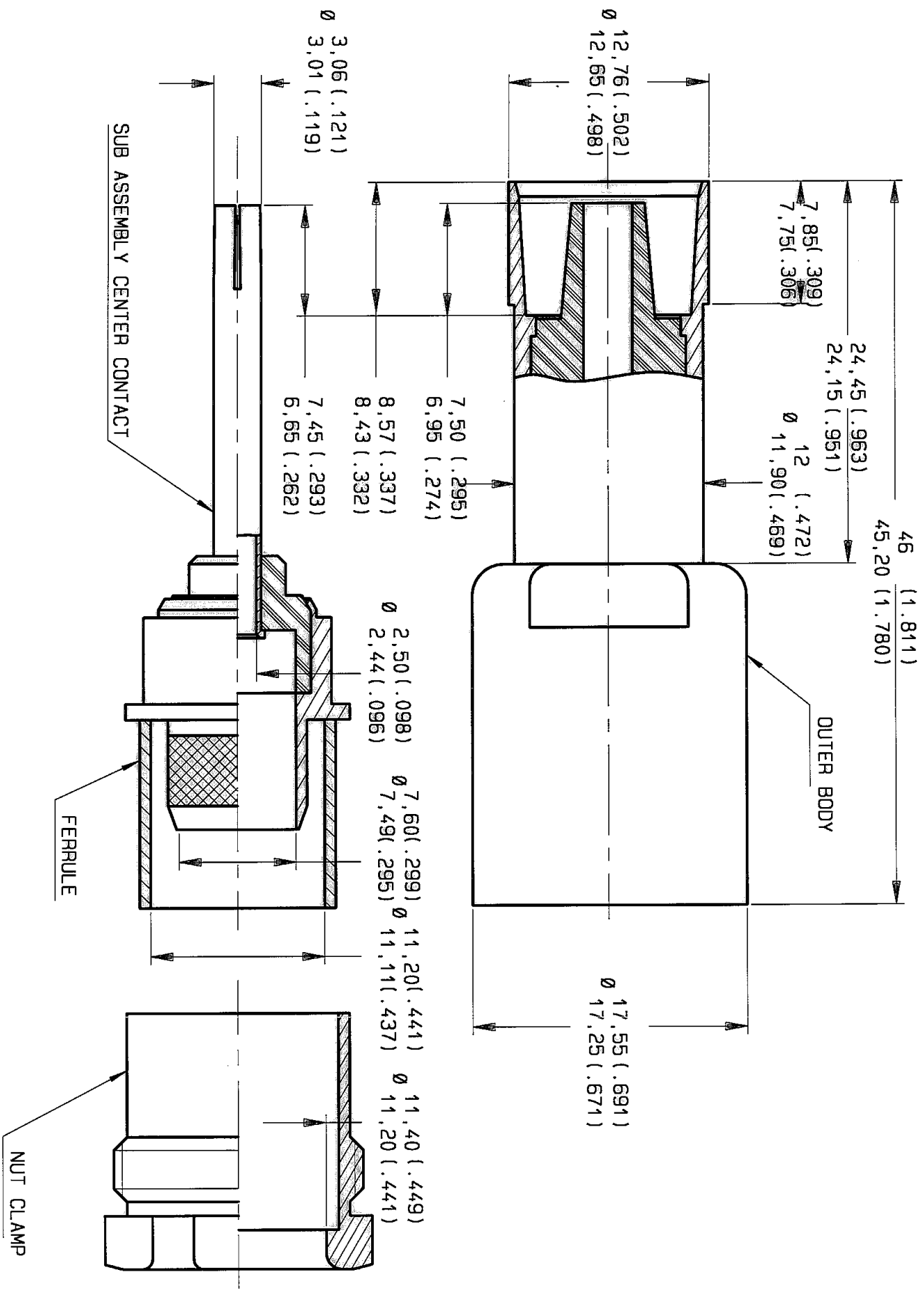

MATERIAL :

OUTER BODY CONTACT AND NUT CLAMP : BRASS PER DC SS handbook V4
 SOCKET CONTACT : BERYLLIUM COPPER PER ASTM-B-196
 FERRULE : ANNEALED BRASS
 INSULATOR : PTFE PER ASTM-D-1710 or EQUIVALENT

PLATING

HARDWARE : GOLD .00005 INCH THICK PER MIL_G_45204 , TYPE I OR II ,
 GRADE C OR D, CLASS 1 OVER NICKEL 00-N-290

INSULATION RESISTANCE : 5000M Ω
 DIELECTRIC WITHSTANDING VOLTAGE : 2500 V RMS AT SEA LEVEL
 VSWR : 1,3 from DC to 5000 MHZ
 IMPEDANCE : 50 Ω

CREATION

PEN: /
 NOM: L FALETTI
 DATE: 01/16/90
 APPR.:

Issue	Revisions	Name	Approved
25/10/00	ADDED RG214, RG393B/U AND PAGE 2/2	26/10/00	SAAGS

RADIALL[®]

101 rue Phillibert Hoffmann Z.I. Ouest
 93116 ROSNY/BOLIS Cedex (France)
 Tl.: 01 49 35 35 35
 Fax.: 01 48 54 63 63
 Tlx: RADIA 235220

4112-9610

This information is given as an indication. In the continual goal to improve our products, we reserve the right to make any modifications judged necessary.

AG10108

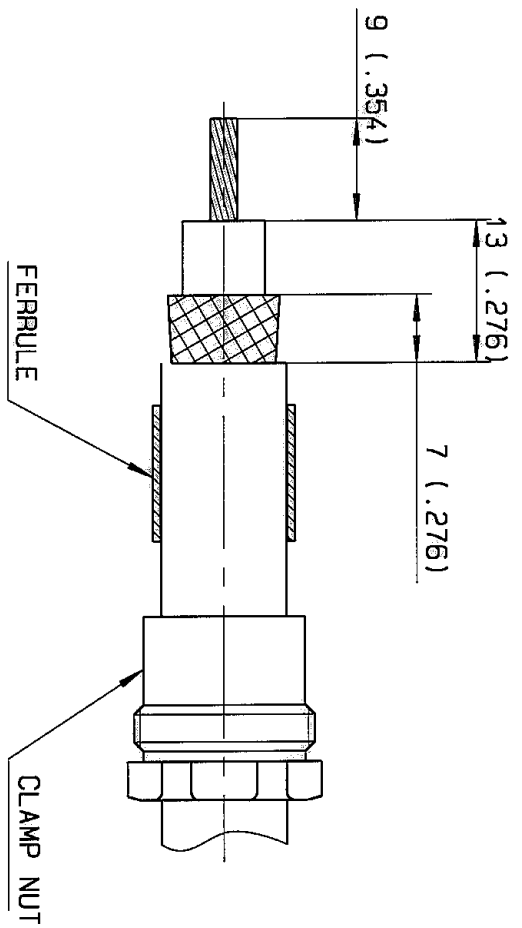

- WIRING INSTRUCTION :
- 1 - SLIDE THE CLAMP NUT THEN THE FERRULE ON THE CABLE THEN STRIP CABLE TO DIMENSIONS SHOWN
 - 2 - AFTER SLIGHTLY FLARING THE BRAID , INSERT THE CONDUCTOR THROUGH THE BARREL IN THE CENTRE CONTACT .

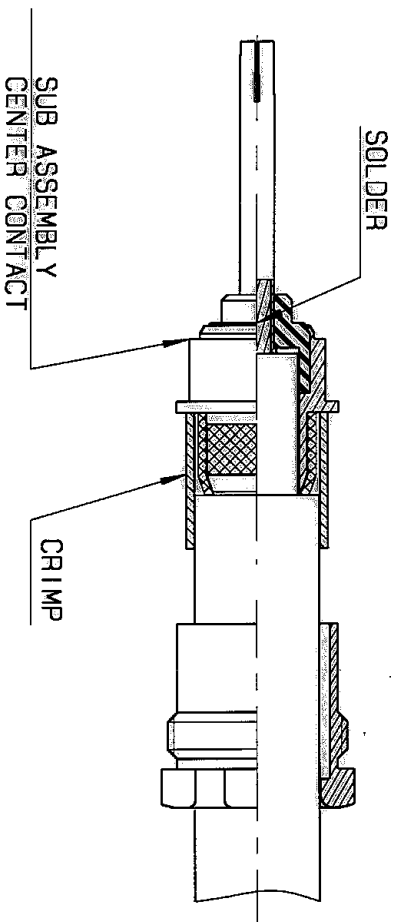

- 3 - FOLD BACK THE BRAID OVER THE BARREL KNURLED SECTION AND SLIDE THE FERRULE OVER THE BRAID
- 4 - CRIMP WITH :
CRIMPING TOOL M22520/5-01 (RADIALL 282293)
DIES M22520/5-61 (RADIALL 282247)
HEX A DIES (10,9 (.429) ON FLATS)

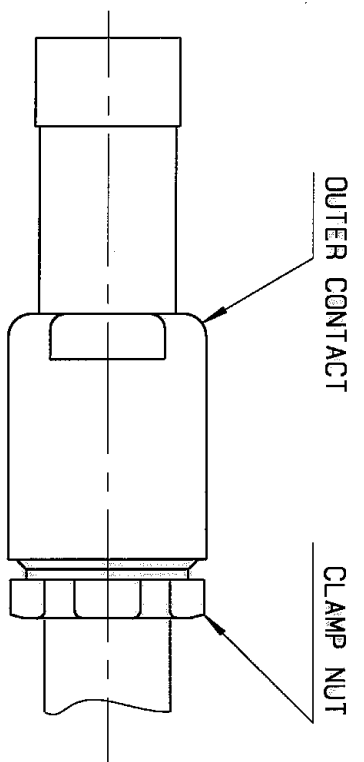

- 5 - INSERT THIS SUB ASSEMBLY IN THE OUTER BODY AND CLAMP NUT TO 5,1 TO 6,2Nm (45 - 55 IN.Lbs TORQUE

ASSEMBLED IN THE CONNECTOR : SHIPPED WITHOUT

