

REEL OF 900 SWITCHS SMT

**R299.137.821**

Series : **DIVERS**

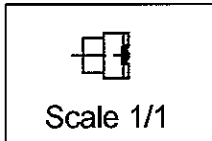
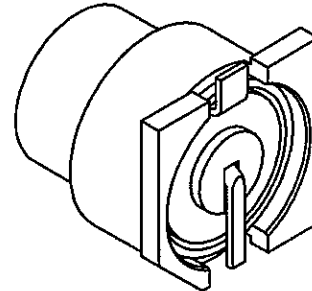
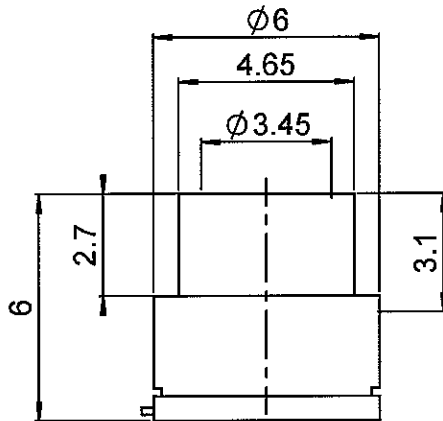
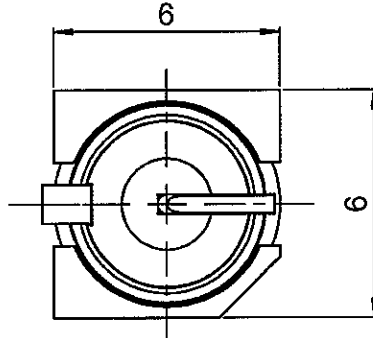

All dimensions are in mm.

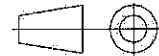

COMPONENTS	MATERIALS	PLATING (µm)
BODY	BRASS	GOLD 0.2 OVER NICKEL 2
CENTER CONTACT	BRASS	GOLD 0.5 OVER NICKEL 2
OUTER CONTACT	-	-
INSULATOR	POLYSULFURE DE PHENYLENE	-
GASKET	-	-
OTHERS PARTS	STAINLESS STEEL	-
-	-	-
-	-	-

Issue : 0530 F

In the effort to improve our products, we reserve the right to make changes judged to be necessary.



REEL OF 900 SWITCHS SMT

**R299.137.821**

Series : **DIVERS**

**PACKAGING**

Standard	Unit	Other
900	'W' option	Contact us

**SPECIFICATION**

**ELECTRICAL CHARACTERISTICS**

Impedance		50 Ω
Frequency		0-4* GHz
VSWR	1.4 +	0.000 x F(GHz) Maxi
Insertion loss		0.2 √F(GHz) dB Maxi
RF leakage	-(	- F(GHz)) dB Maxi
Voltage rating		100 Veff Maxi
Dielectric withstanding voltage		350 Veff mini
Insulation resistance		5000 MΩ mini

**ENVIRONMENTAL**

Operating temperature	-40/+110 °C
Hermetic seal	NA Atm.cm3/s
Panel leakage	NA

**OTHER CHARACTERISTICS**

Assembly instruction

Others :

isol. between 2 ways:-25 dBmin at 2 GHz

\*Usable 0 to 6GHz

**MECHANICAL CHARACTERISTICS**

Center contact retention		
Axial force – Mating end	NA	N mini
Axial force – Opposite end	NA	N mini
Torque	NA	N.cm mini
Recommended torque		
Mating	NA	N.cm
Panel nut	NA	N.cm
Mating life	80000	Cycles mini
Weight	0.098	g

Issue : 0530 F

In the effort to improve our products, we reserve the right to make changes judged to be necessary.



**RADIALL®**

REEL OF 900 SWITCHS SMT

**R299.137.821**

Series : **DIVERS**

**SOLDER PROCEDURE**

1. Deposition of solder paste 'Sn Ag4 Cu0.5' on mounting zone by screen printing application. We recommend a low residue flux.  
We advise a thickness of 150 microns mini ( 0.006 inch mini ). Verify that the edges of the zone are clean.
2. Placement of the receptacle on the mounting zone with an automatic machine of 'pick and place' type.  
Video camera is recommended for the positioning of the component. Adhesive agents must not be used on the receptacle.
3. Soldering by infra-red reflow.  
Below, please find the typical profile to use.
4. Cleaning of printed circuit boards.
5. Checking of solder joints and position of the component by visual inspection.

**TEMPERATURE PROFILE**

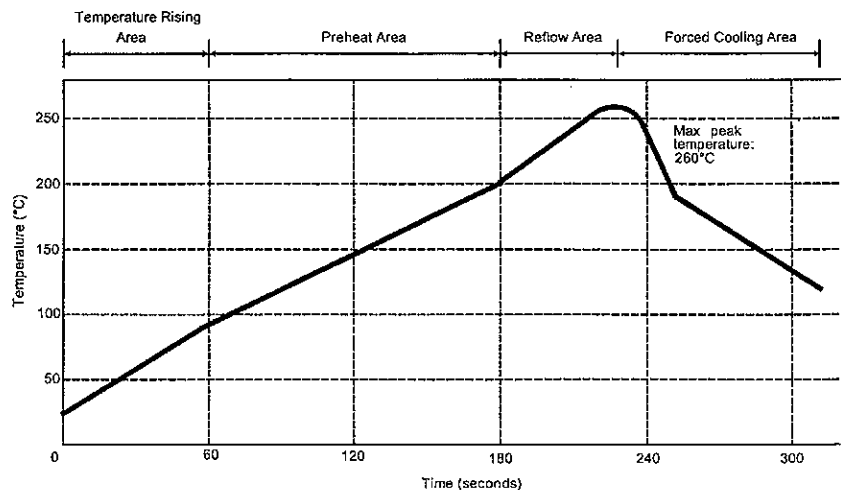

Parameter	Value	Unit
Temperature rising Area	1 - 4	°C/sec
Max Peak Temperature	260	°C
Max dwell time @260°C	10	sec
Min dwell time @235°C	20	sec
Max dwell time @235°C	60	sec
Temperature drop in cooling Area	-1 to - 4	°C/sec
Max dwell time above 100°C	420	sec

Issue : 0530 F

In the effort to improve our products, we reserve the right to make changes judged to be necessary.



REEL OF 900 SWITCHS SMT

**R299.137.821**

Series : **DIVERS**

**STRAIGHT SWITCH CMS**

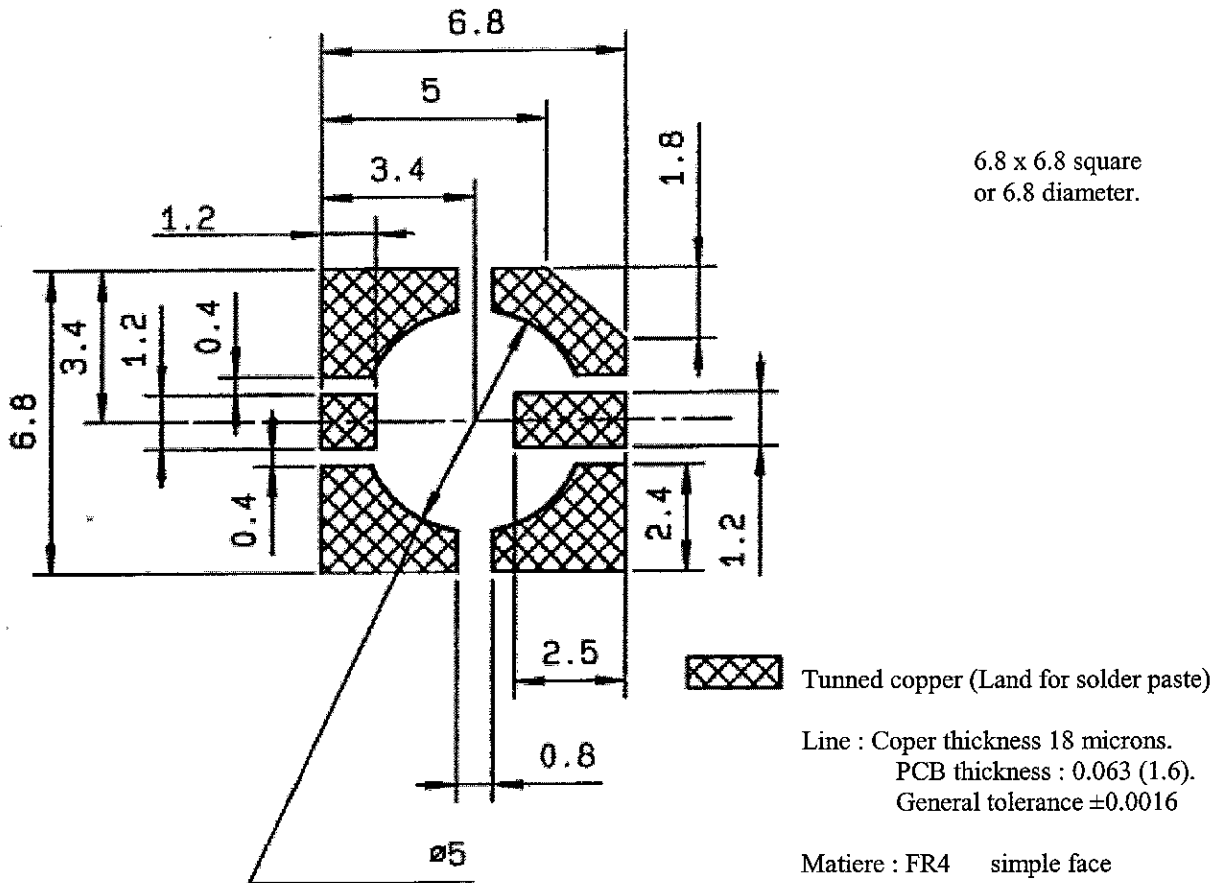

**AIR SUNCTION**

**SHADOW FOR VIDEO**

**CAMERA**

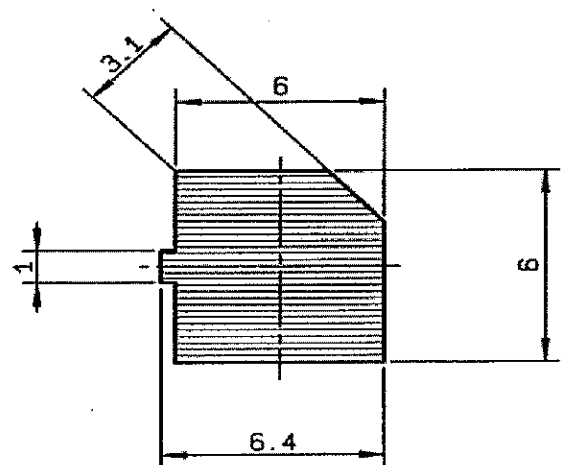
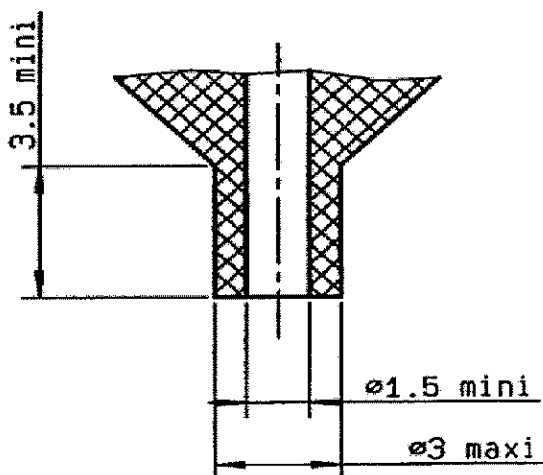

Issue : 0530 F

In the effort to improve our products, we reserve the right to make changes judged to be necessary.



REEL OF 900 SWITCHS SMT

**R299.137.821**

Series : **DIVERS**

**VSWR 1.3 max unmated**  
**VSWR 1.4 max mated**

**STRAIGHT SWITCH CMS**

**VSWR**  
**(Measured performance)**

Switch connected with R299.138  
Auxiliary antenna .Way 2  
Switch alone (no connected)  
Mobile phone antenna .Way 1

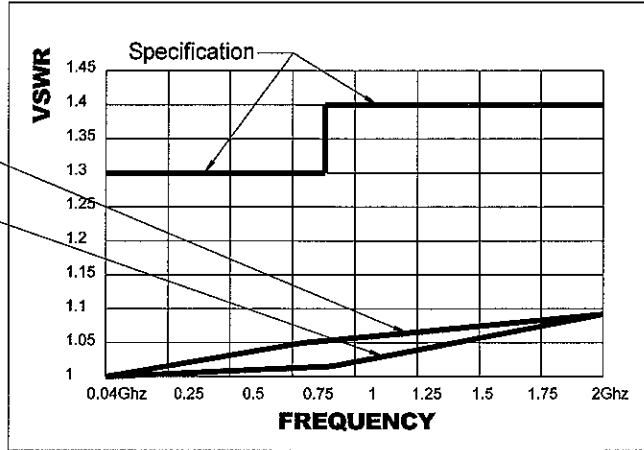
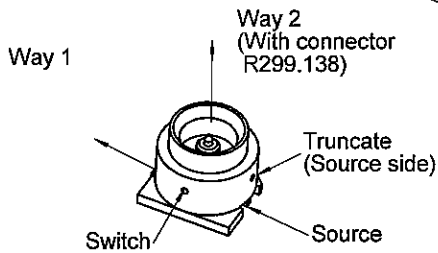

**INSERTION LOSS**  
**(Measured performance)**

Switch connected with R299.138

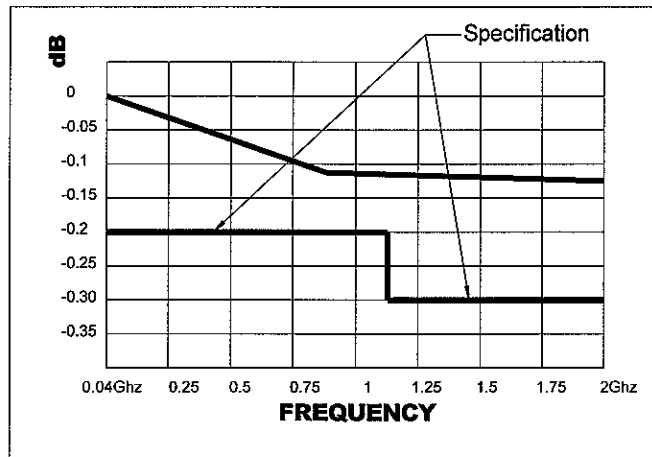
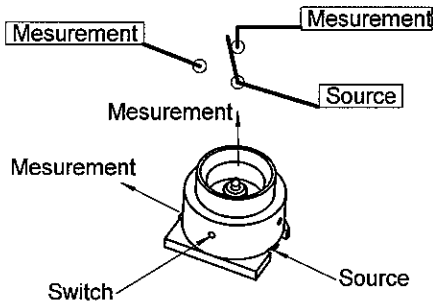

**0-2 Ghz -> - .2dBmax. unmated**  
**-> - .3dB max mated**

**ISOLATION**  
**(Measured performance)**

Switch connected with R299.138

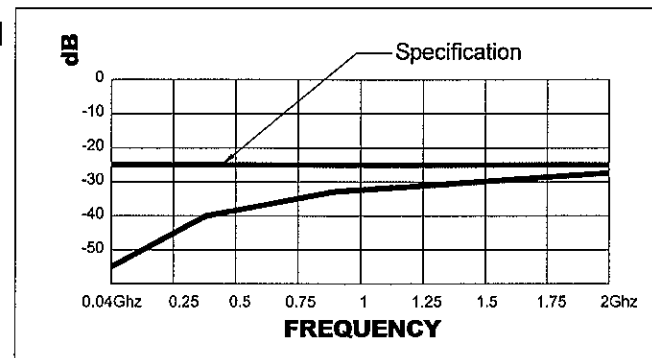
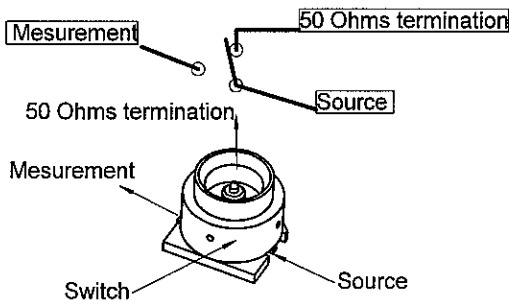

**0-2 Ghz -> -25dB Max**

**STRAIGHT SWITCH CMS**

Issue : 0530 F

In the effort to improve our products, we reserve the right to make changes judged to be necessary.



REEL OF 900 SWITCHS SMT

**R299.137.821**

Series : **DIVERS**

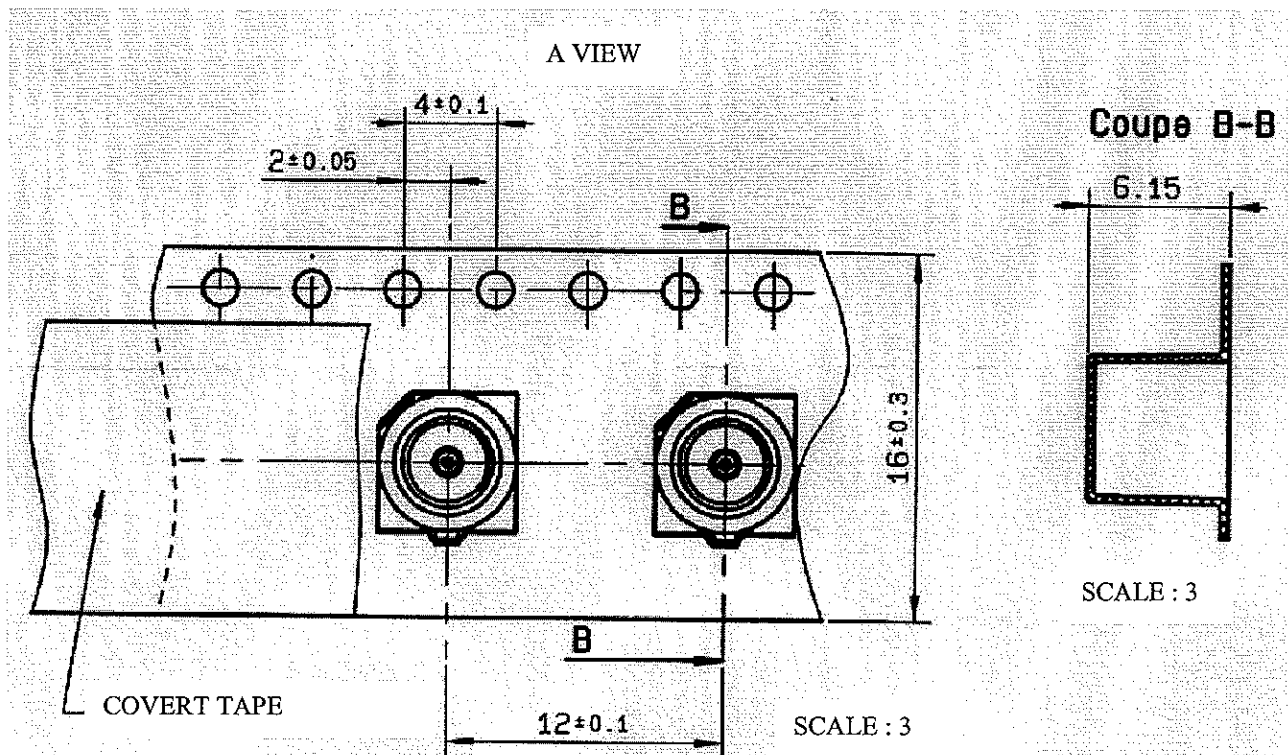
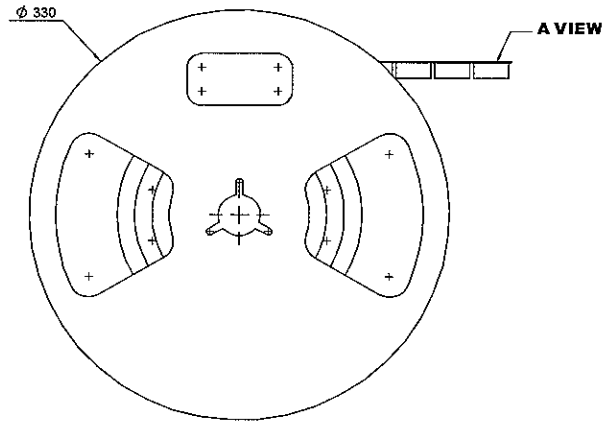

Issue : 0530 F

In the effort to improve our products, we reserve the right to make changes judged to be necessary.



**RADIALL**®