

PAGE 1/3	ISSUE 1445 B	SERIES SMP LOCK	PART NUMBER R222L20020
----------	--------------	-----------------	------------------------

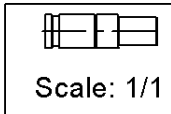

All dimensions are in mm.

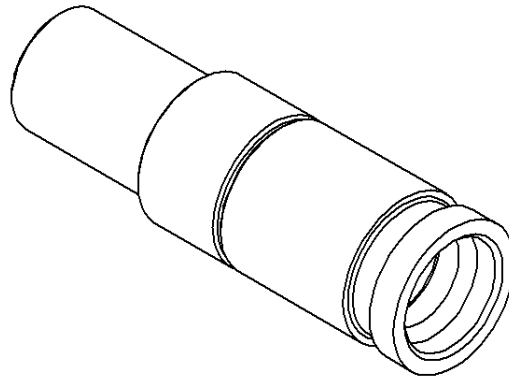
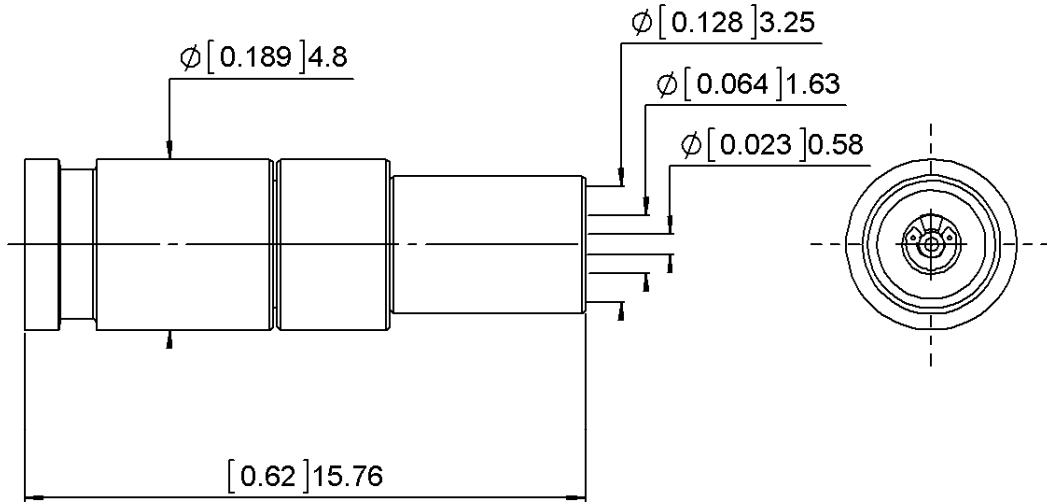
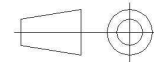

COMPONENTS	MATERIALS	PLATING (µm)
Body	BRASS.	GOLD 1.3 OVER NICKEL 2
Center contact	COPPER-NICKEL-TIN ALLOY	GOLD 1.27 OVER NICKEL 1.27
Outer contact		
Insulator	PEEK	
Gasket		
Others parts	BRASS.	GOLD 1.3 OVER NICKEL 2
-	-	
-	-	

PAGE 2/3	ISSUE 1445 B	SERIES SMP LOCK	PART NUMBER R222L20020
----------	--------------	-----------------	------------------------

PACKAGING

Standard	Unit	Other
100	Contact us	Contact us

ELECTRICAL CHARACTERISTICS

Impedance	50	Ω
Frequency	0-26.5	GHz
VSWR	1.06* + 0.0000	x F(GHz) Maxi
Insertion loss	0.12*	√F(GHz) dB Maxi
RF leakage	NA	- F(GHz) dB Maxi
Voltage rating	335	Veff Maxi
Dielectric withstanding voltage	500	Veff mini
Insulation resistance	5000	MΩ mini

MECHANICAL CHARACTERISTICS

Center contact retention		
Axial force – Mating End	6.7	N mini
Axial force – Opposite end	6.7	N mini
Torque	NA	N.cm mini
Recommended torque		
Mating	NA	N.cm
Panel nut	NA	N.cm
Clamp nut	NA	N.cm
A/F clamp nut	0.0000	mm
Mating life	500	Cycles mini
Weight	0.8300	g

ENVIRONMENTAL

Operating temperature	-40/+250	°C
Hermetic seal	NA	Atm.cm3/s
Panel leakage		

SPECIFICATION

CABLE ASSEMBLY

Stripping	a	b	c	d	e	f
mm	2.3	4.8	8.03	0	5.73	0

Assembly instruction:

Recommended cable(s)

ECO 316
RG 188
RG 316
KX 22A

Characteristics indicated on this data sheet are those that can be achieved with the highest performance cable. Intrinsic limitations of the cable may diminish the performance of the assembly

Cable retention

- pull off	110	N mini
- torque	NA	N.cm

TOOLING

Part Number	Description	Hexagon
R282211000	CRIMPING TOOL	3.25
R282235003	CRIMPING DIES M22520/5-03	3.25
R282293000	CRIMPING TOOL M22520/5-01	

OTHER CHARACTERISTICS

*VSWR & IL up to 3GHz

PAGE 3/3	ISSUE 1445 B	SERIES SMP LOCK	PART NUMBER R222L20020
----------	--------------	-----------------	------------------------

COMPONENTS

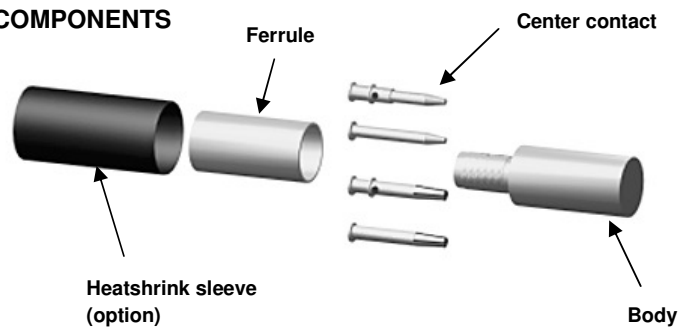

STRIPPING DIMENSIONS

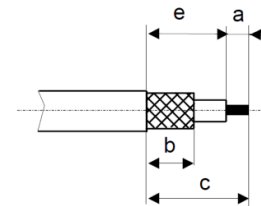

1

Slide the heatshrink sleeve onto the cable.
Slide the ferrule onto the cable.
Strip the cable.

4

Slide the cable into the body until it bottoms against the internal socket contact.

IMPORTANT: Centre contact must maintain concentricity to dielectric as it slides for precise alignment into the socket contact, or else risk of short circuit can occur.

2

Slide the centre contact on until it bottoms against the cable dielectric.
Solder the centre contact, keeping the centre contact and dielectric concentric.
Clean solder area.

5

Slide the ferrule over the braid.
Crimp the ferrule with crimping tool (see connector TDS).

3

Fan the braid.

6

Cut the excess of braid if necessary.
Slide the sleeve over the ferrule and heatshrink it in place.

NOTE: Additional cable constraint is recommended in vibration conditions at 20 G-rms.