

**STRAIGHT JACK SOLDER TYPE  
FOR CABLE SHF2.4M - 38999 SERIES**

**R199.012.052**

Series : MCC #12

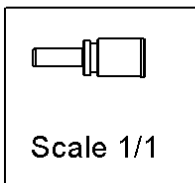
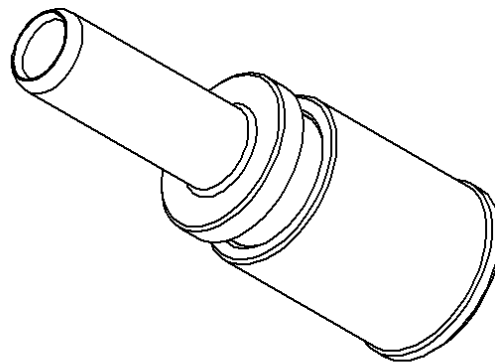
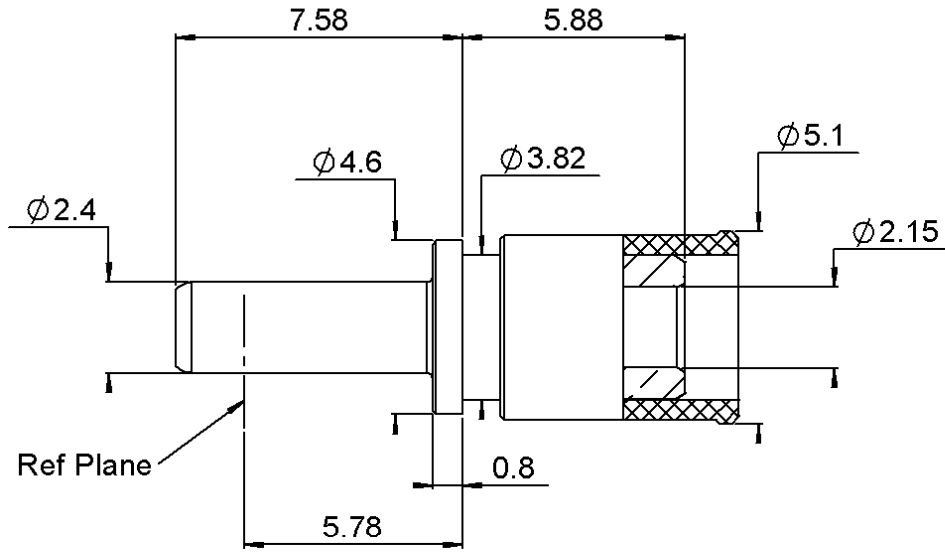

All dimensions are in mm.

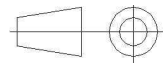

COMPONENTS	MATERIALS	PLATING ( $\mu\text{m}$ )
BODY	BERYLLIUM COPPER	GOLD 1.3 OVER NICKEL 2
CENTER CONTACT	BERYLLIUM COPPER	GOLD 1.3 OVER NICKEL 2
OUTER CONTACT	-	-
INSULATOR	PTFE+PEEK	-
GASKET	-	-
OTHERS PARTS	BERYLLIUM COPPER	GOLD 0.5 OVER NICKEL 2
SLEEVE	ULTEM	-
-	-	-

Issue : 1430 A

In the effort to improve our products, we reserve the right to make changes judged to be necessary.



**STRAIGHT JACK SOLDER TYPE  
FOR CABLE SHF2.4M - 38999 SERIES**

**R199.012.052**

Series : MCC #12

**PACKAGING**

Standard	Unit	Other
<b>100</b>	<b>'W' option</b>	<b>Contact us</b>

**SPECIFICATION**

**ELECTRICAL CHARACTERISTICS**

Impedance		<b>50</b> Ω
Frequency		<b>0-40</b> GHz
VSWR	* +	<b>0,0000</b> x F(GHz) Maxi
Insertion loss		<b>0.12</b> √F(GHz) dB Maxi
RF leakage	- (	<b>**</b> - F(GHz)) dB Maxi
Voltage rating		<b>335</b> Veff Maxi
Dielectric withstanding voltage		<b>1000</b> Veff mini
Insulation resistance		<b>5000</b> MΩ mini

**CABLE ASSEMBLY**

Stripping	a	b	c	d	e	f
mm	1,80	0,00	0,00	0,00	0,00	0,00

Assembly instruction :

Recommended cable(s)  
SHF2.4M

Characteristics indicated on this data sheet are those that can be achieved with the highest performance cable. Intrinsic limitations of the cable may diminish the performance of the assembly

Cable retention

- pull off	<b>40</b> N mini
- torque	<b>NA</b> N.cm

**MECHANICAL CHARACTERISTICS**

Center contact retention		
Axial force – Mating end	<b>6.7</b>	N mini
Axial force – Opposite end	<b>6.7</b>	N mini
Torque	<b>NA</b>	N.cm mini

**TOOLING**

**See page3**

Recommended torque		
Mating	<b>NA</b>	N.cm
Panel nut	<b>NA</b>	N.cm
Clamp nut	<b>NA</b>	N.cm
A/F clamp nut	<b>0,0000</b>	mm

Part Number	Description	Hexagon
.	.	.

Mating life	<b>500</b>	Cycles mini
Weight	<b>0,6600</b>	g

**OTHER CHARACTERISTICS**

\*1.15 (DC-26 GHz)1.25 (26GHz-40GHz )  
\*\*-80dB (DC-3 GHz) -65dB (3 GHz-26GHz)

**ENVIRONMENTAL**

Operating temperature	<b>-65/+165</b>	° C
Hermetic seal	<b>NA</b>	Atm.cm3/s
Panel leakage	<b>NA</b>	

Issue : 1430 A

In the effort to improve our products, we reserve the right to make changes judged to be necessary.



**STRAIGHT JACK SOLDER TYPE  
FOR CABLE SHF2.4M - 38999 SERIES**

**R199.012.052**

Series : MCC #12

**COMPONENT**

**STRIPPING DIMENSION**

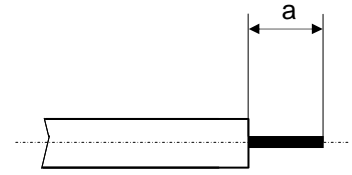
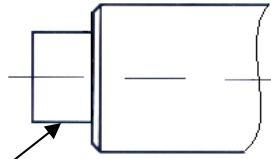

CONNECTOR BODY

We recommend a thermal preconditioning of the cable.

**1**

Strip the cable.

Trim cable center conductor.

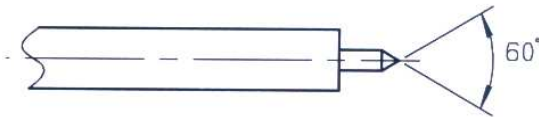

**2**

Slide cable into connector body until it contacts the body shoulder.  
Place sub assembly into the assembly jig : R282.740.000 (or equivalent)  
Solder body onto cable.  
Let the assembly cool down before removing it from the jig.  
Clean the solder area.

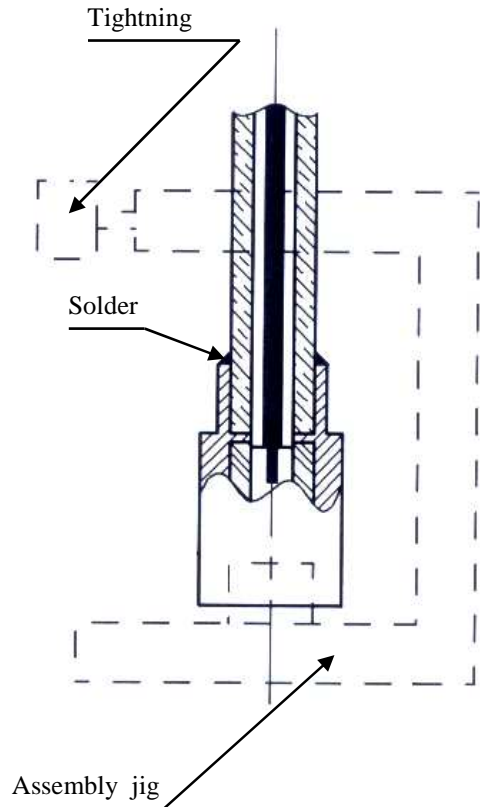

Issue : 1430 A

In the effort to improve our products, we reserve the right to make changes judged to be necessary.

