

STRAIGHT BULKHEAD JACK CRIMP TYPE

R185.314.100

CABLE 6.1/50D

Series : 7-16

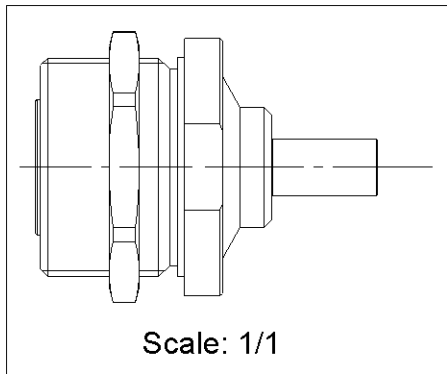
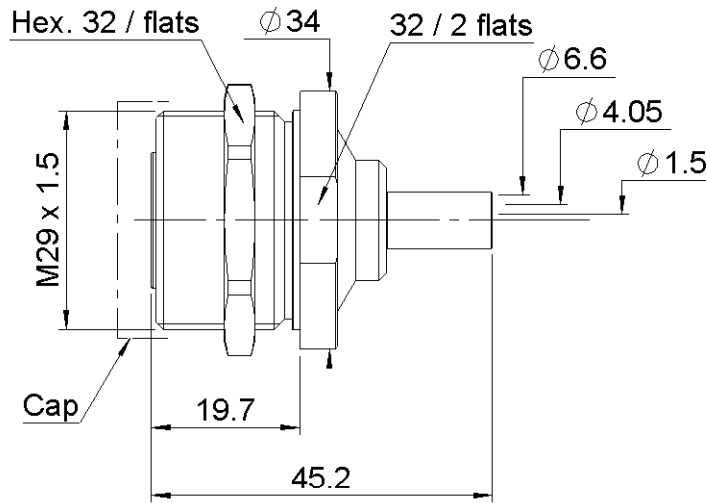

PANEL CUT OUT

A

mm	
Maxi	mini
A	29.2
	29.1

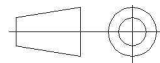
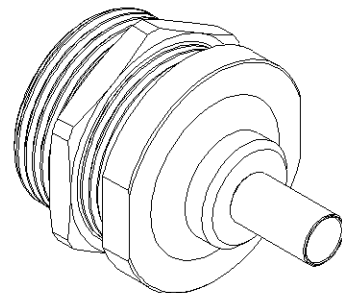

All dimensions are in mm.

COMPONENTS	MATERIALS	PLATING (µm)
BODY	BRASS	BBR
CENTER CONTACT	BRONZE, BRASS	SILVER OVER COPPER
OUTER CONTACT	BRASS	SILVER OVER COPPER
INSULATOR	PTFE	
GASKET		
OTHERS PARTS	BRASS	BBR
-	-	-
-	-	-

Issue : 1239 B

In the effort to improve our products, we reserve the right to make changes judged to be necessary.



STRAIGHT BULKHEAD JACK CRIMP TYPE

R185.314.100

CABLE 6.1/50D

Series : 7-16

PACKAGING

Standard	Unit	Other
20	-	Contact us

SPECIFICATION

ELECTRICAL CHARACTERISTICS

Impedance		50 Ω
Frequency		0-7.5 GHz
VSWR	*1.2 +	0,0000 x F(GHz) Maxi
Insertion loss		0.05 √F(GHz) dB Maxi
RF leakage	- (95 - F(GHz)) dB Maxi
Voltage rating		850 Veff Maxi
Dielectric withstanding voltage		1500 Veff mini
Insulation resistance		10000 MΩ mini

CABLE ASSEMBLY

Stripping	a	b	c	d	e	f
mm	5,40	10,0	17,4	0,00	12,0	0,00

Assembly instruction : **SEE PAGE 3**

Recommended cable(s)

KSR240

LMR 240

Characteristics indicated on this data sheet are those that can be achieved with the highest performance cable. Intrinsic limitations of the cable may diminish the performance of the assembly

Cable retention

- pull off **220** N mini
- torque **NA** N.cm

MECHANICAL CHARACTERISTICS

Center contact retention		
Axial force – Mating end	200	N mini
Axial force – Opposite end	100	N mini
Torque	NA	N.cm mini

TOOLING

Part Number	Description	Hexagon
.	.	.
R282.223.000	CRIMPING TOOL	
R282.235.013	CRIMPING DIES	
R282.293.000	CRIMPING TOOL M22520/5-01	

Recommended torque		
Mating	NA	N.cm
Panel nut	600	N.cm
Clamp nut	NA	N.cm
A/F clamp nut	0,0000	mm

Mating life	500	Cycles mini
Weight	114,5200	g

OTHER CHARACTERISTICS

* 1.10 a 3 GHz

ENVIRONMENTAL

Operating temperature	-55/+155	° C
Hermetic seal	NA	Atm.cm3/s
Panel leakage	NA	

Issue : 1239 B

In the effort to improve our products, we reserve the right to make changes judged to be necessary.



STRAIGHT BULKHEAD JACK CRIMP TYPE

R185.314.100

CABLE 6.1/50D

Series : 7-16

COMPONENTS

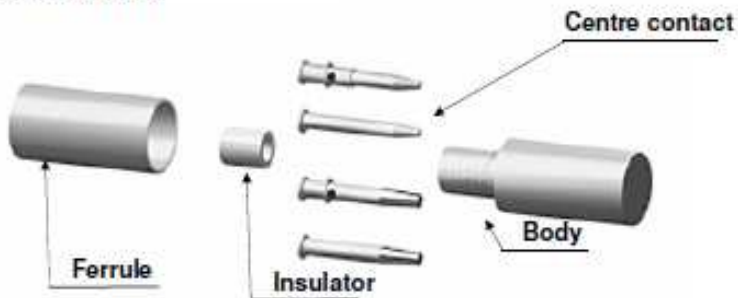

STRIPPING DIMENSIONS

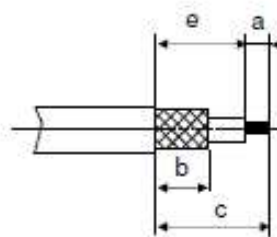

1

Slide the ferrule onto the cable.
Strip the cable.



4

Slide cable into body until it bottoms against insulator.



2

Fan the braid.
Slide the insulator on the cable centre contact until it bottoms against the cable dielectric.



5

Slide the ferrule over the braid.



3

Slide on the centre contact until it bottoms against the additional insulator.
Solder the centre contact with crimping tool.
Clean solder area if necessary.



6

Crimp the ferrule with crimping tool (see connector TDS).
Cut the excess of braid if necessary.

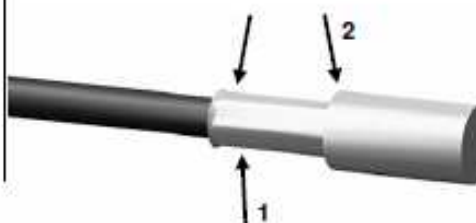

Issue : 1239 B

In the effort to improve our products, we reserve the right to make changes judged to be necessary.

