

**RIGHT ANGLE PLUG CLAMP TYPE
CABLE 7/50 DTR.**

R166.160.020
SERIES **C**

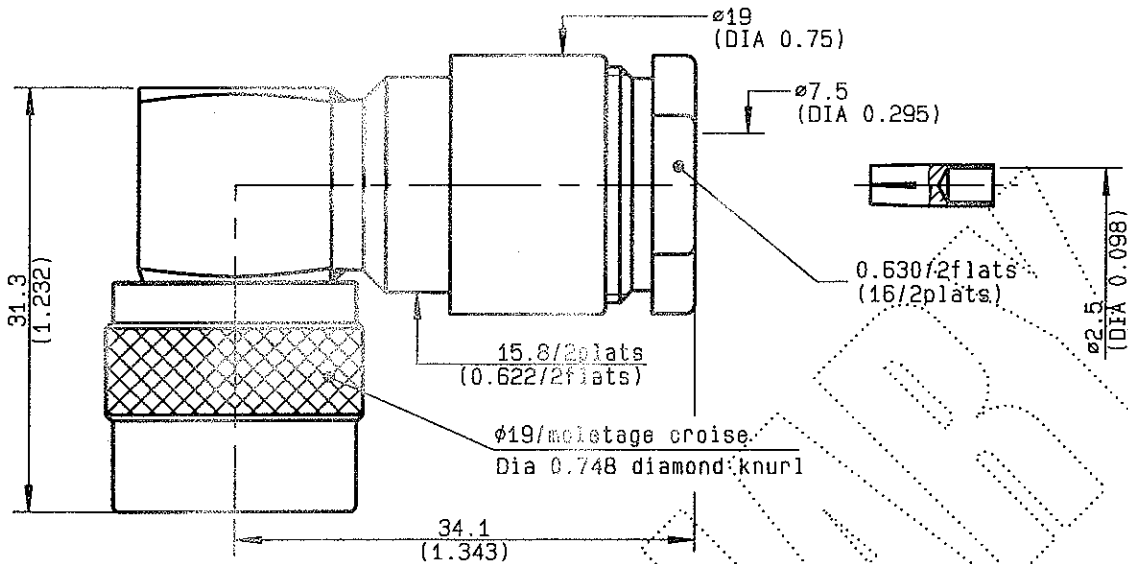

NOMINAL IMPEDANCE	50 Ω	CABLES	AA-5887
FREQUENCY RANGE	0-11 GHz		
TEMPERATURE RATING	-65/+165 °C		
V.S.W.R	1.4 _{max} + x.F.(GHz)Maxi		
RF INSERTION LOSS	1.35 \sqrt{F} (GHz) dB·Maxi		
VOLTAGE RATING	1000 V _{eff} Maxi		
DIELECTRIC WITHSTANDING VOLTAGE	3000 V _{eff} Mini		
INSULATION RESISTANCE	5000 M Ω Mini	OTHERS CHARACTERISTICS	
HERMETIC SEAL	NA Atm.cm ³ /s		* 1.4 at 0 - 6 GHz.
LEAKAGE (pressurized only)	NA	CABLE RETENTION	180 N Mini
MECHANICAL DURABILITY	500 Cycles	CENTER CONTACT RETENTION	
WEIGHT	g ^r	Axial force - mating end	NA N Mini
SPECIFICATION		Axial force - opposite end	NA N Mini
		Torque	NA cm.N Mini
		RECOMMENDED TORQUES	
		Mating	NA cm.N
		Panel nut	NA cm.N
		Clamp nut	450 cm.N

CONNECTOR PARTS	MATERIALS	FINISH	(all values are given) in micrometers
BODY	BRASS	NICKEL 2	
OUTER CONTACT	BRONZE	NICKEL 2	
CENTER CONTACT	BERYLLIUM COPPER, BRASS	GOLD 0.5 OVER NICKEL 2	
INSULATOR	PTFE	-	
GASKET	SILICONE RUBBER	-	
OTHERS PIECES	BRASS	BBR 2	

ZAN. E
ISSUE 9945A00
CREATION DATE 30/08/1999
FILE PART-NUMBER 99-0103-584



The information given here is subject to change without notice.
Design changes may be in order to improve the product.

Connect to the future



R166.160.020

ISSUE 9945A00 SERIES C

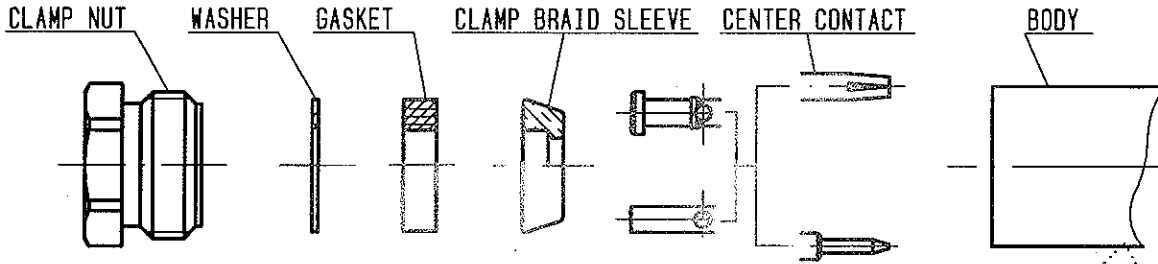

①

Strip the cable .

-
-
-
-

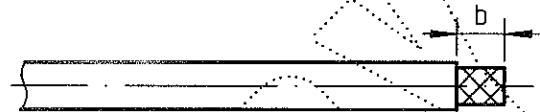

Stripping	a	b	c	d	e
inch	0.138	0.276	0	0	0.051
mm	3.5	7			1.3

②

Slide the clamp nut , the washer and the gasket onto the cable .
Slide clamp braid sleeve over braid .
Fold back braid and trim off excess of braid .
Cut the foil .
Trim back dielectric as shown .

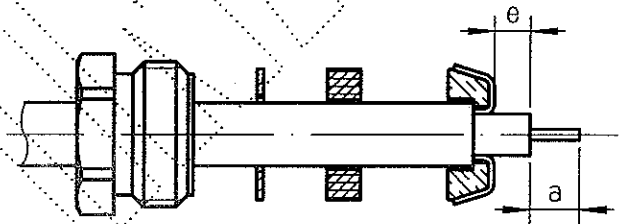

③

Solder the cable inner conductor into center contact .

-
-
-
-

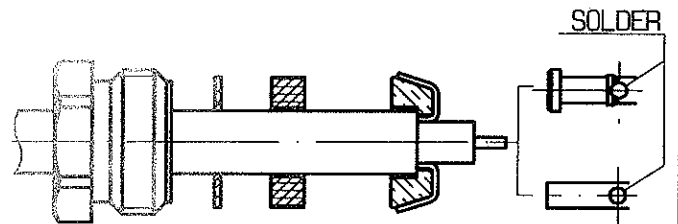

④

Screw sub-assembly into the connector body .
(recommended coupling torque 39.83 in.lb)

-
-

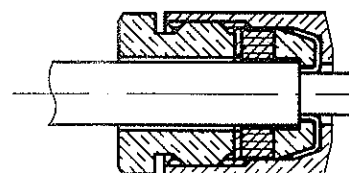

Hex. : 0.63/flats