

PAGE 1/3	ISSUE 19-10-15D	SERIES TNC	PART NUMBER R143297700
----------	-----------------	------------	------------------------

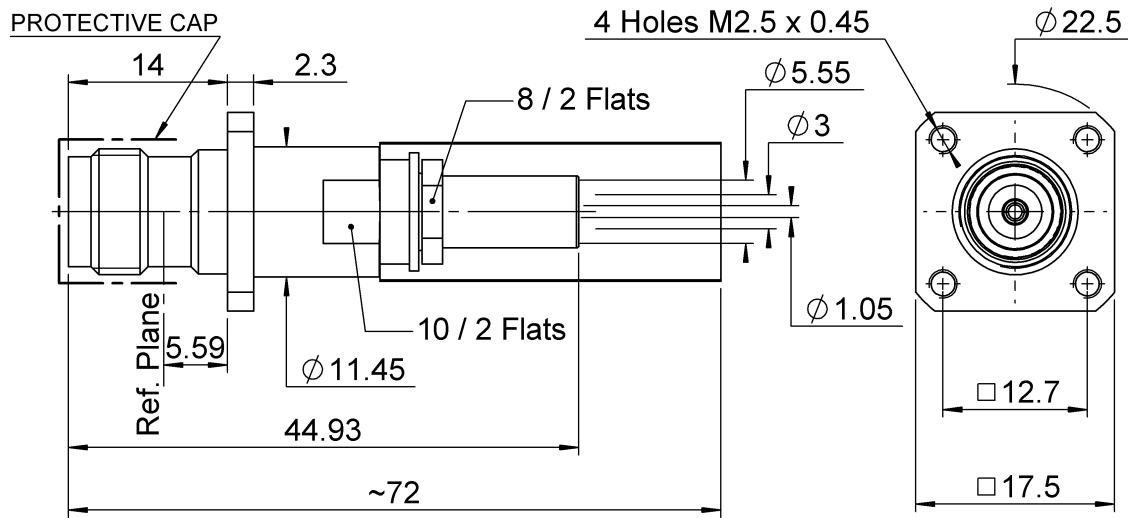

**PANEL CUT OUT**

	mm	
	Maxi	mini
<b>A</b>	11.3	11.2
<b>B</b>	2.7	2.6
<b>C</b>	12.75	12.65

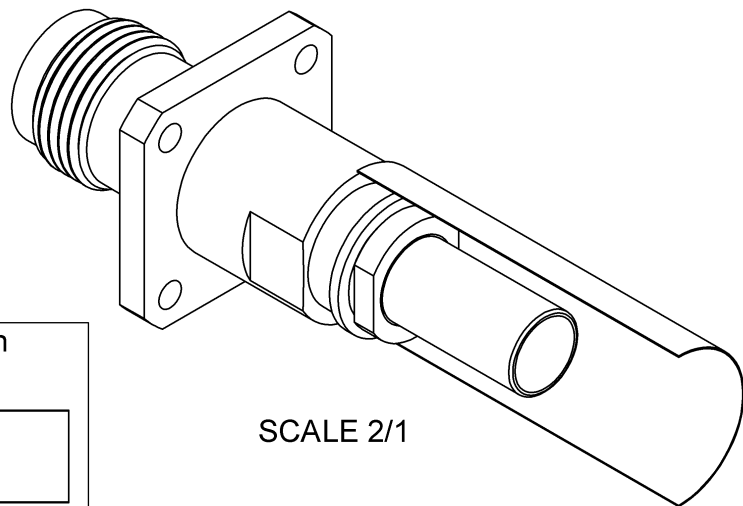
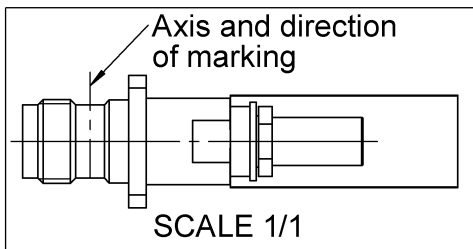

All dimensions are in mm.

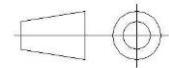

COMPONENTS	MATERIALS	PLATING (µm)
Body	<b>STAINLESS STEEL</b>	<b>PASSIVATED.</b>
Center contact	<b>BERYLLIUM COPPER</b>	<b>GOLD 0.5 OVER NICKEL 2</b>
Outer contact	-	-
Insulator	<b>PTFE</b>	-
Gasket	-	-
Others parts	<b>BRASS</b>	<b>NICKEL 2</b>
-	-	-
-	-	-

PAGE <b>2/3</b>	ISSUE <b>19-10-15D</b>	SERIES <b>TNC</b>	PART NUMBER <b>R143297700</b>
-----------------	------------------------	-------------------	-------------------------------

### PACKAGING

Standard	Unit	Other
<b>1</b>	<b>Contact us</b>	<b>Contact us</b>

### ELECTRICAL CHARACTERISTICS

Impedance	<b>50</b>	$\Omega$
Frequency	<b>0-6</b>	GHz
VSWR	<b>1.2 + 0,0000</b>	x F(GHz) Maxi
Insertion loss	<b>0.06</b>	$\sqrt{F}$ (GHz) dB Maxi
RF leakage	- ( <b>57*</b> )	- F(GHz)) dB Maxi
Voltage rating	<b>500</b>	Veff Maxi
Dielectric withstanding voltage	<b>1500</b>	Veff mini
Insulation resistance	<b>5000</b>	M $\Omega$ mini

### MECHANICAL CHARACTERISTICS

Center contact retention		
Axial force – Mating End	<b>NA</b>	N mini
Axial force – Opposite end	<b>NA</b>	N mini
Torque	<b>NA</b>	N.cm mini
Recommended torque		
Mating	<b>NA</b>	N.cm
Panel nut	<b>NA</b>	N.cm
Clamp nut	<b>170</b>	N.cm
A/F clamp nut	<b>8,0000</b>	mm
Mating life	<b>500</b>	Cycles mini
Weight	<b>19,9500</b>	g

### ENVIRONMENTAL

Operating temperature	<b>-65/+165</b>	$^{\circ}\text{C}$
Hermetic seal	<b>NA</b>	Atm.cm3/s
Panel leakage	<b>NA</b>	

### SPECIFICATION

**ASN-E0461 TC01 - -**

### CABLE ASSEMBLY

Stripping	a	b	c	d	e	f
mm	<b>9</b>	<b>9</b>	<b>23</b>	<b>0</b>	<b>0</b>	<b>0</b>

Assembly instruction:

Recommended cable(s)

**KX 23**  
**RG 142 FTX**  
**RG 142 BU**  
**RG 400**  
**RG 223**

Characteristics indicated on this data sheet are those that can be achieved with the highest performance cable. Intrinsic limitations of the cable may diminish the performance of the assembly

Cable retention

- pull off	<b>180</b>	N mini
- torque	<b>NA</b>	N.cm

### TOOLING

Part Number	Description	Hexagon
282291	CRIMPING TOOL M22520/1-01	2x4 (pos7)
282997	POSITIONER FOR TOOL 282.291(M22520/1-13)	rouge
R282223000	CRIMPING TOOL	5.41

### OTHER CHARACTERISTICS

**\*Up to 3 GHz**

PAGE 3/3	ISSUE 19-10-15D	SERIES TNC	PART NUMBER R143297700
----------	-----------------	------------	------------------------

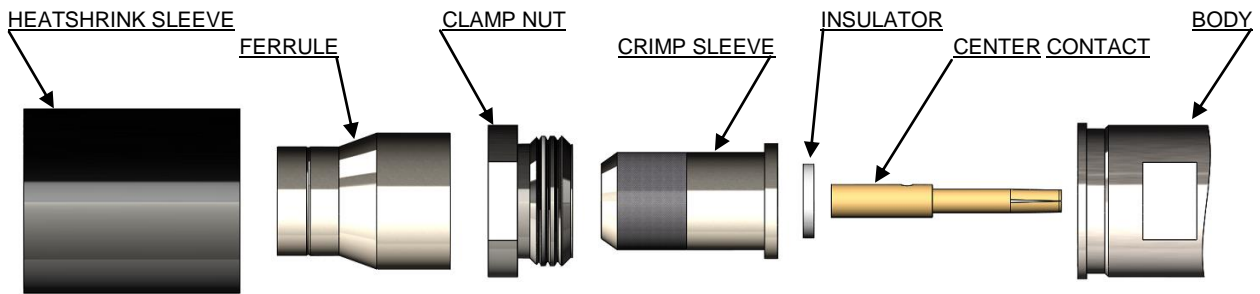

**1**

Slide onto the cable the heatshrink sleeve and the ferrule  
Strip the cable.  
Optionally, to facilitate the stripping of the inner cable, the length "a" could be stripped after crimping of the ferrule.

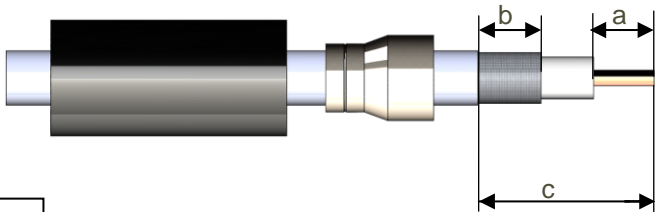

**2**

Slide the clamp nut onto the crimp sleeve.  
Slide sub-assembly under the braid.  
Slide ferrule over the braid against clamp nut. (In direction F)  
Crimp the ferrule with crimping tool + dies

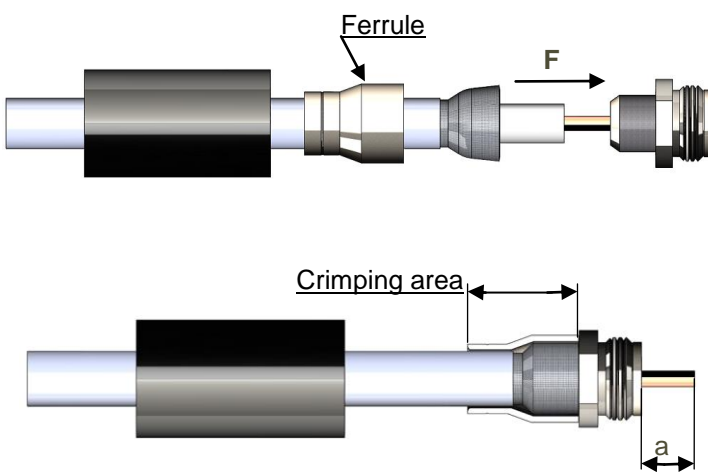

**3**

The dielectric must be in the same plane as the face of the crimp sleeve. Cut the dielectric flush to crimp sleeve if it exceeds. Clean the dielectric side.  
Mount insulator against crimp sleeve.

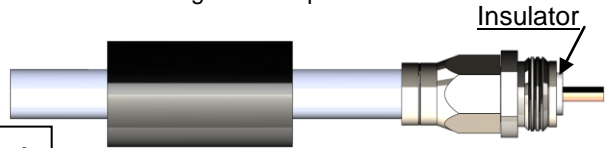

**4**

Slide the center contact onto the cable inner conductor against insulator.  
Crimp the center contact with the crimping tool and the positioner.

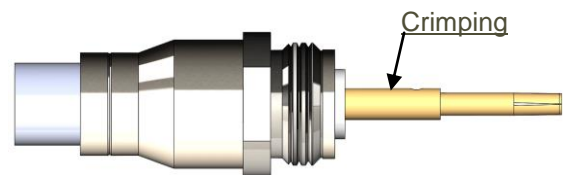

**5**

Screw sub-assembly into the connector body. (recommended coupling see the connector TDS)  
Slide sleeve heatshrink over ferrule and put in the place as below

