

PAGE 1/3	ISSUE 1439A	SERIES BMA	PART NUMBER R128639071
----------	-------------	------------	------------------------

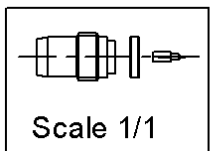

All dimensions are in mm.

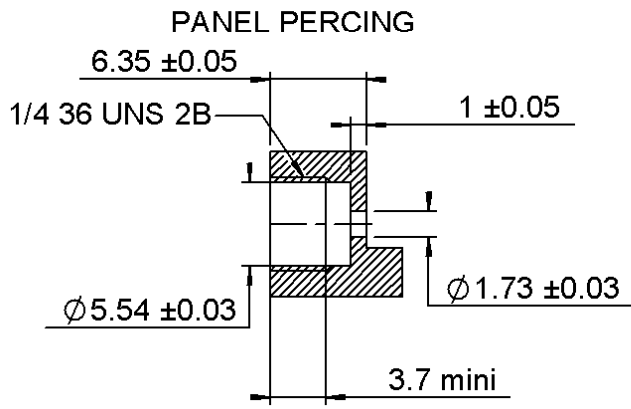
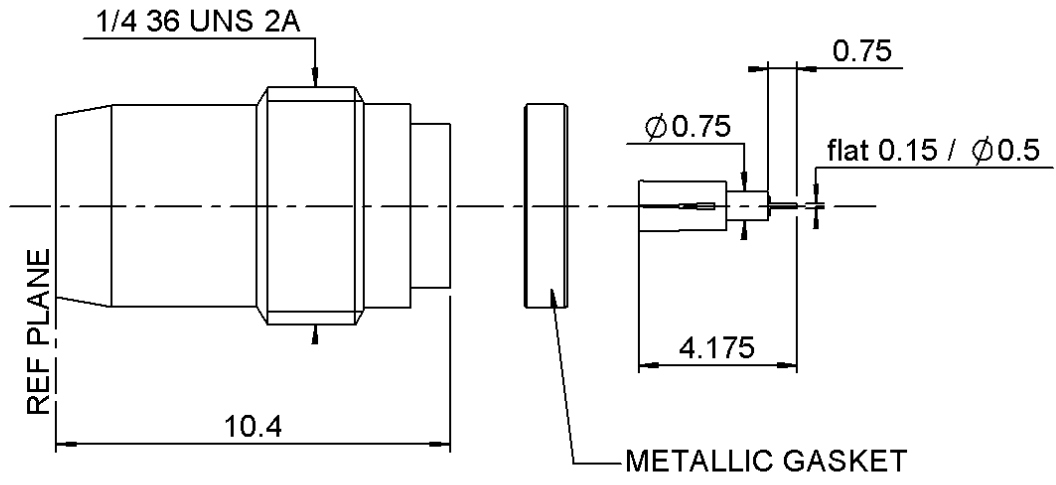
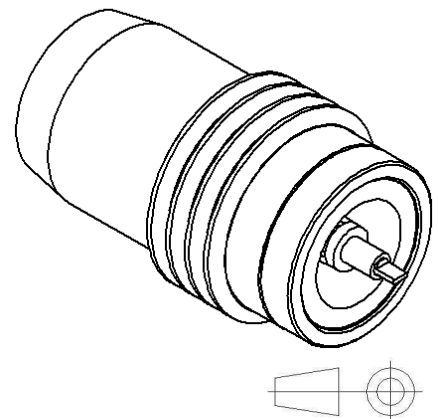

COMPONENTS	MATERIALS	PLATING (µm)
Body	STAINLESS STEEL	PASSIVATED.
Center contact	BERYLLIUM COPPER	GOLD 1.3 OVER NICKEL2
Outer contact	-	-
Insulator	PTFE+GLASS BEAD	-
Gasket	ALUMINIUM ALLOY	GOLD 1.3 OVER NICKEL2
Others parts	DILVER P1	-
-	-	-
-	-	-

PAGE 2/3	ISSUE 1439A	SERIES BMA	PART NUMBER R128639071
----------	-------------	-------------------	-------------------------------

PACKAGING

Standard	Unit	Other
100	Contact us	Contact us

ELECTRICAL CHARACTERISTICS

Impedance		50	Ω
Frequency		0-22	GHz
VSWR	1.25	+	0,0000 x F(GHz) Maxi
Insertion loss		0.07	√F(GHz) dB Maxi
RF leakage	- (NA	- F(GHz)) dB Maxi
Voltage rating		500	Veff Maxi
Dielectric withstanding voltage		1500	Veff mini
Insulation resistance		5000	MΩ mini

ENVIRONMENTAL

Operating temperature	-65/+125	°C
Hermetic seal	10-8	Atm.cm3/s
Panel leakage	NA	

MECHANICAL CHARACTERISTICS

Center contact retention			
Axial force – Mating End		27	N mini
Axial force – Opposite end		27	N mini
Torque		NA	N.cm mini
Recommended torque			
Mating		NA	N.cm
Panel nut		280	N.cm
Mating life		1000	Cycles mini
Weight		1,2020	g

SPECIFICATION

OTHER CHARACTERISTICS

Assembly instruction:**NA**

Others:

PAGE 3/3	ISSUE 1439A	SERIES BMA	PART NUMBER R128639071
----------	-------------	------------	------------------------

PANEL DRILLING

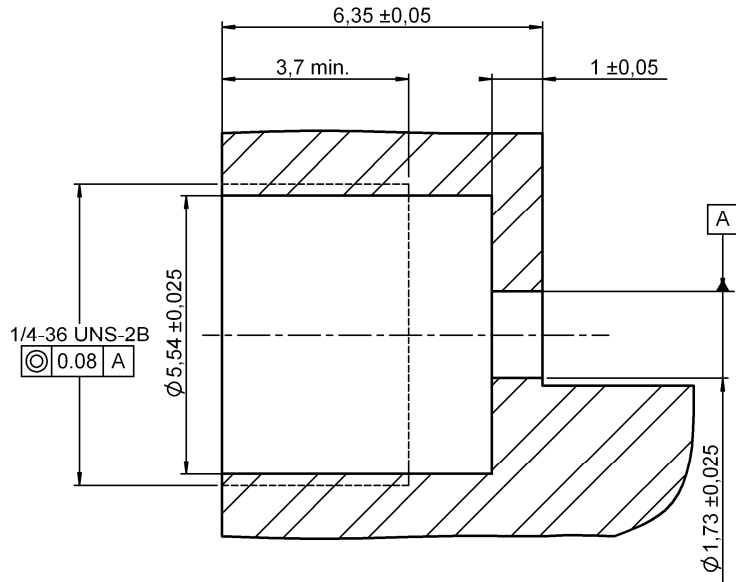

MOUNTING HOLE DETAIL

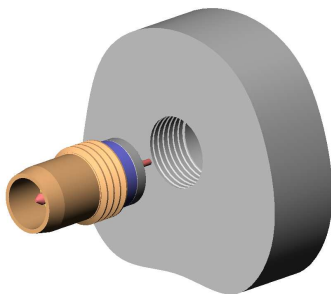
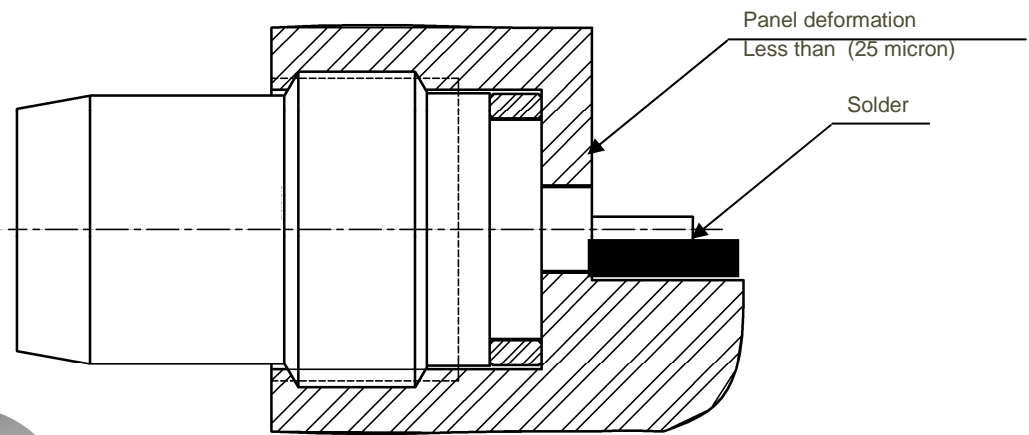

Assemble metal gasket onto connector. Screw both parts into the housing. Tighten the connector up to $280 \pm 10\text{Ncm}$ torque (use special tooling set RADIALL R282 340). Thus the connection hermeticity is guaranteed at $1 \cdot 10^{-8} \text{ atm.cm}^3/\text{sec}$. Then solder the pin. Be careful not put too much solder.