

NON GLASS HERMETIC RECEPTACLE
, SCREW-IN TYPE

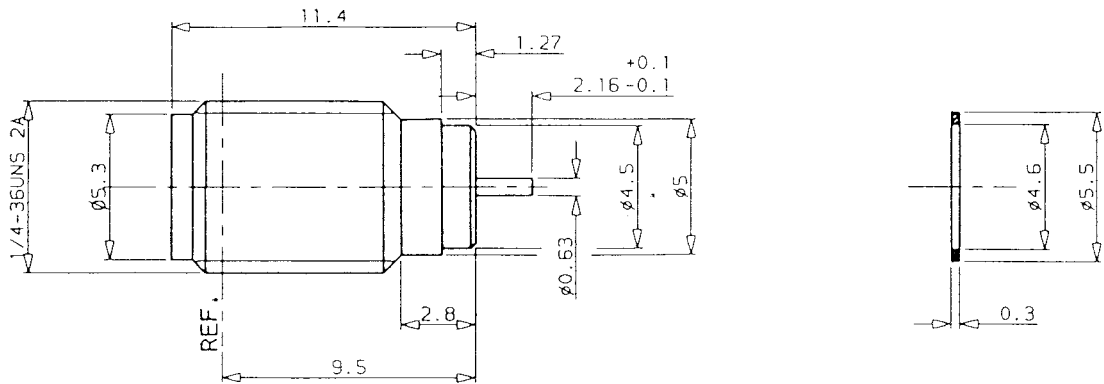

BURN IN : At the end of manufacturing, connector is submitted to a burn in test as follows:

Progressive increase of temperature from +25°C to +125°C . Maintain high temperature (+125°C) for 2 hours .

CHARACTERISTICS

NOMINAL IMPEDANCE	50 Ω	STANDARDISATION	MIL C 39012
FREQUENCY RANGE	DC-18 GHz		-
TEMPERATURE RATING	-55/+150 °C		-
VSWR	1.20 Max	MATING TORQUE RECOMMENDED	7.088-8.86 inch. Lb 80-100 cm.N
RF INSERTION LOSS	0.2 dB Max	CENTER CONTACT RETENTION	
VOLTAGE RATING	450 Vrms	Axial force - mating end	3.375 lb min 15 N min
DIELECTRIC WITHSTANDING VOLTAGE	1000 Vrms	Axial force - opposite end	3.375 lb min 15 N min
INSULATION RESISTANCE	5000 M Ω	Torque (Max)	NA inch.oz NA cm.N
HERMETIC SEAL	6.10 ⁻⁷ cc/s cm ³ /s		
-	-		
-	-		
-	-		

CONSTRUCTION

CONNECTOR PARTS	MATERIALS	FINISH
Body	Stainless steel	Passivated
Center contact	Beryllium copper	Gold over copper
-	-	-
Insulators	PTFE	-
Gasket	Brass	Gold over copper
-	-	-
-	-	-
-	-	-
-	-	-

ISSUE	REVISION No	DESCRIPTION	BY	DATE

Initiated on 12-10-88
Superseded on 23-02-95

The information given here is subject to change without notice. Design changes may be in order to improve the product.



NON GLASS HERMETIC RECEPTACLE
, SCREW-IN TYPE

SERIES:

SMA

PANEL DRILLING

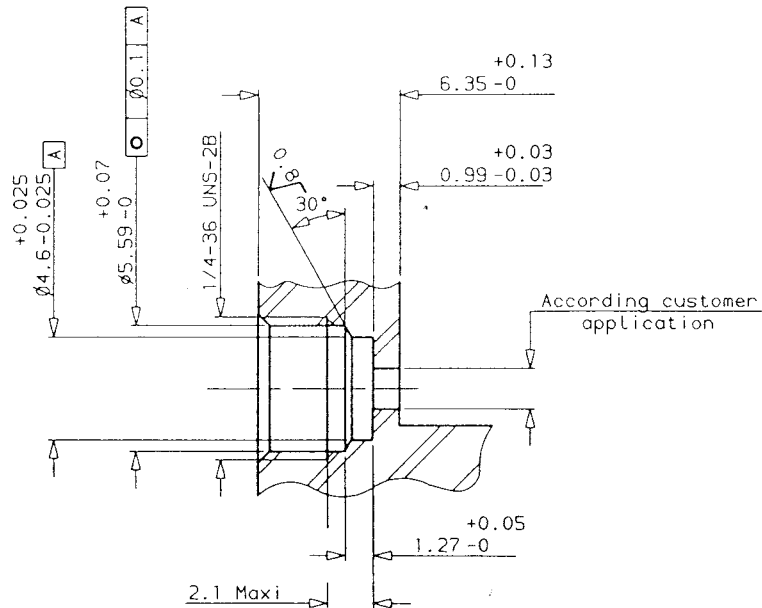

RECOMMENDED MOUNTING HOLE DETAIL

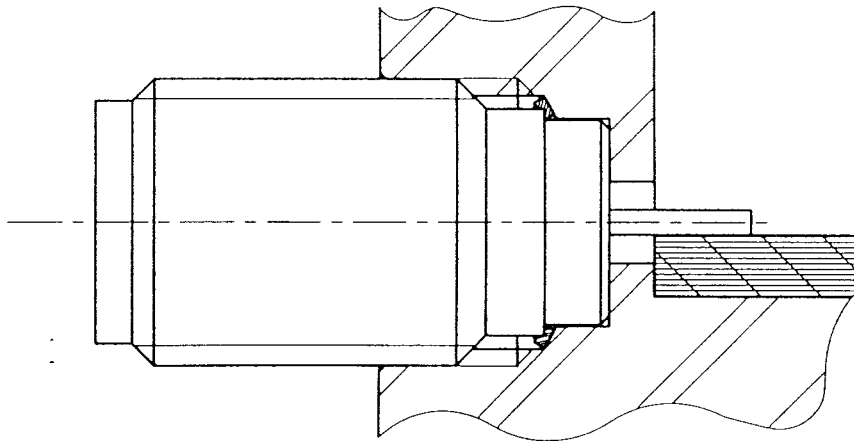

Assemble metal gasket onto connector. Screw both parts into the housing.
Tighten the connector up to 25 Inch-Pounds torque (use special tooling set
RADIALL R282 341 012).

ISSUE	REVISION No	DESCRIPTION	BY	DATE
.
.
.

Initiated on 12-10-88

The information given here is subject to change without notice. Design changes may be in order to improve the product.



Superseded on 23-02-95