

STRAIGHT SQUARE FLANGE JACK SOLDER TYPE

R125.256.000

CABLE .085

Series : SMA

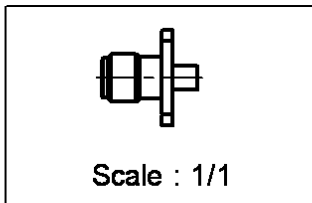
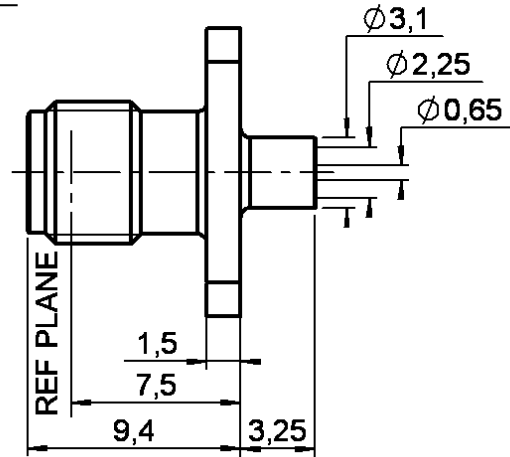
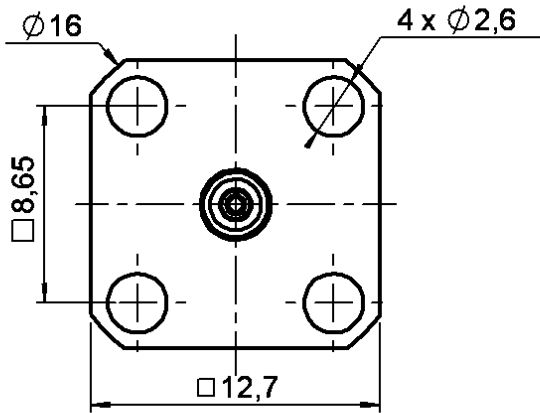

PANEL CUT OUT

	mm	
	Maxi	mini
A	6.6	6.5
B	2.7	2.6
C	8.69	8.59

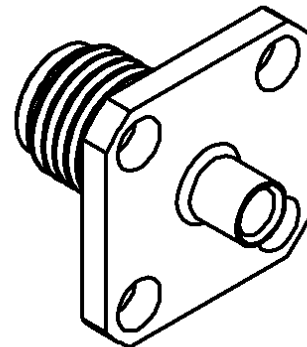

All dimensions are in mm.

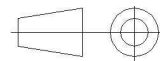

COMPONENTS	MATERIALS	PLATINGS (µm)
BODY	STAINLESS STEEL	GOLD 0.5 OVER NICKEL 2
CENTER CONTACT	BERYLLIUM COPPER	GOLD 1.3 OVER NICKEL 2
OUTER CONTACT	-	-
INSULATOR	PTFE	-
GASKET	-	-
OTHERS PARTS	-	-
-	-	-
-	-	-

Issue : 0829 H

In the effort to improve our products, we reserve the right to make changes judged to be necessary.



STRAIGHT SQUARE FLANGE JACK SOLDER TYPE

R125.256.000

CABLE .085

Series : SMA

PACKAGING

Standard	Unit	Other
100	'W' option	Contact us

SPECIFICATION

CABLE ASSEMBLY

Stripping	a	b	c	d	e	f
mm	3,17	0,00	0,00	0,00	0,00	0,00

ELECTRICAL CHARACTERISTICS

Impedance		50	Ω
Frequency		0-18	GHz
VSWR	1.07 +	0,0080	x F(GHz) Maxi
Insertion loss		0.03	\sqrt{F} (GHz) dB Maxi
RF leakage	- (90	- F(GHz)) dB Maxi
Voltage rating		335	Veff Maxi
Dielectric withstanding voltage		750	Veff mini
Insulation resistance		5000	M Ω mini

Assembly instruction : **Solder 01**

Recommended cable(s)
RG 405
KS 1

Characteristics indicated on this data sheet are those that can be achieved with the highest performance cable. Intrinsic limitations of the cable may diminish the performance of the assembly

Cable retention

- pull off **130** N mini
- torque **NA** N.cm

MECHANICAL CHARACTERISTICS

Center contact retention		
Axial force – Mating end	NA	N mini
Axial force – Opposite end	NA	N mini
Torque	NA	N.cm mini

Recommended torque		
Mating	NA	N.cm
Panel nut	NA	N.cm
Clamp nut	NA	N.cm
A/F clamp nut	0,0000	mm

Mating life	500	Cycles mini
Weight	2,5850	g

TOOLING

Part Number	Description	Hexagon
R282.120.010	SMA TOOLBOX	
R282.744.010	SOLDERING POSITIONER (BODY)	
R282.914.010	DIELETRIC RECESS GAUGE	
R282.915.010	DIELECTRIC RECESS TOOL	
R282.730.043	INSULATOR MOUNTING TOOL	
R282.740.000	SOLDERING MOUNTING	
R282.744.220	SOLDERING POSITIONER (CENTER CONTACT)	
R282.862.060	CONTROL GAUGE	
R282.063.000	POINTER GAUGE	
R282.051.000	STRIPPING TOOL	

ENVIRONMENTAL

Operating temperature	-65/+105	$^{\circ}$ C
Hermetic seal	NA	Atm.cm3/s
Panel leakage	NA	

OTHERS CHARACTERISTICS

Issue : 0829 H

In the effort to improve our products, we reserve the right to make changes judged to be necessary.

