

STRAIGHT JACK RECEPTACLE FOR PCB

R124.427.000

SMT TYPE

Series : SMA-COM

4 indents captivation c. contact
(Tenue c. central par 4 creves)

*set back of c. contact from body
(Retrait du c. central/ au corps)

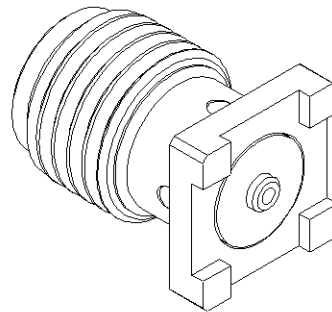
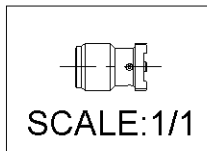
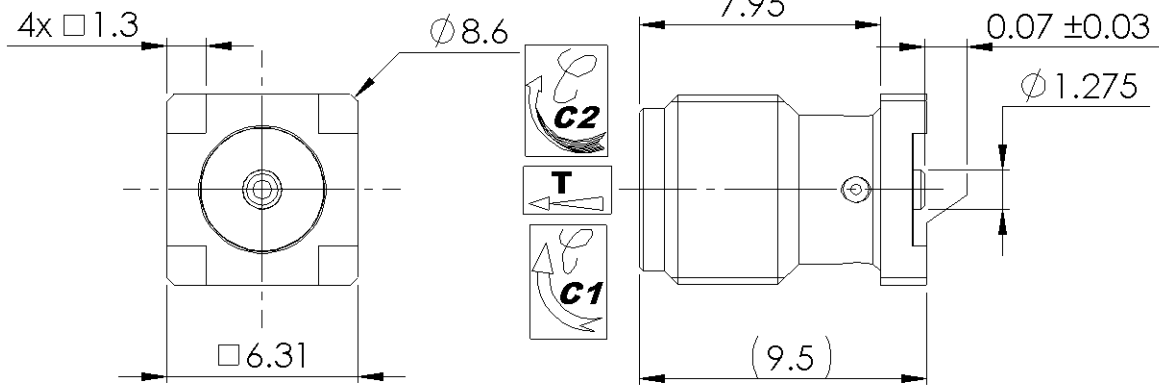

All dimensions are in mm.

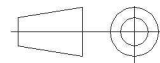

COMPONENTS	MATERIALS	PLATING (µm)
BODY	BRASS	GOLD OVER NICKEL
CENTER CONTACT	BERYLLIUM COPPER	GOLD OVER NICKEL
OUTER CONTACT	-	--
INSULATOR	PTFE	
GASKET	-	
OTHERS PARTS	-	--
-	-	-
-	-	-

Issue : 1138 B

In the effort to improve our products, we reserve the right to make changes judged to be necessary.



STRAIGHT JACK RECEPTACLE FOR PCB

R124.427.000

SMT TYPE

Series : SMA-COM

PACKAGING

SPECIFICATION

Standard	Unit	Other
100	'W' option	Contact us

ELECTRICAL CHARACTERISTICS

ENVIRONMENTAL

Impedance	50	Ω
Frequency	0-18	GHz
VSWR	1.04 + 0.0450	x F(GHz) Maxi
Insertion loss	0.05	\sqrt{F} (GHz) dB Maxi
RF leakage	- (100)	- F(GHz) dB Maxi
Voltage rating	500	Veff Maxi
Dielectric withstanding voltage	1000	Veff mini
Insulation resistance	5000	M Ω mini

Operating temperature	-65/+165	$^{\circ}$ C
Hermetic seal	NA	Atm.cm3/s
Panel leakage	NA	

OTHER CHARACTERISTICS

Assembly instruction

Others :
FORCE F1:100N-TORQUES C1:70Ncm-C2:90Ncm

MECHANICAL CHARACTERISTICS

Center contact retention		
Axial force – Mating end	15	N mini
Axial force – Opposite end	15	N mini
Torque	1	N.cm mini
Recommended torque		
Mating	-	N.cm
Panel nut	NA	N.cm
Mating life	100	Cycles mini
Weight	1.1000	g

Issue : 1138 B

In the effort to improve our products, we reserve the right to make changes judged to be necessary.



STRAIGHT JACK RECEPTACLE FOR PCB

R124.427.000

SMT TYPE

Series : SMA-COM

SOLDER PROCEDURE

1. Deposition of solder paste ‘Sn Ag4 Cu0.5’ on mounting zone by screen printing application. We recommend a low residue flux.
We advise a thickness of 150 microns mini (.006 inch). Verify that the edges of the zone are clean.
2. Placement of the receptacle on the mounting zone with an automatic machine of ‘pick and place’ type. Aspiration port centered into body and push against it.
Video camera is recommended for the positioning of the component. Adhesive agents must not be used on the receptacle.
3. Soldering by infra-red reflow.
Below, please find the typical profile to use.
4. Cleaning of printed circuit boards.
5. Checking of solder joints and position of the component by visual inspection.

TEMPERATURE PROFILE

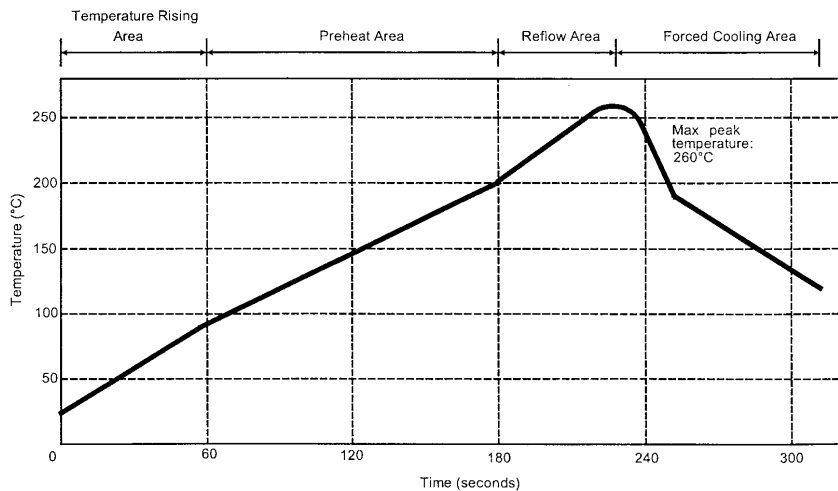

Parameter	Value	Unit
Temperature rising Area	1 - 4	°C/sec
Max Peak Temperature	260	°C
Max dwell time @260°C	10	sec
Min dwell time @235°C	20	sec
Max dwell time @235°C	60	sec
Temperature drop in cooling Area	-1 to - 4	°C/sec
Max dwell time above 100°C	420	sec

Issue : 1138 B

In the effort to improve our products, we reserve the right to make changes judged to be necessary.



STRAIGHT JACK RECEPTACLE FOR PCB

R124.427.000

SMT TYPE

Series : SMA-COM

SMA B SERIES - INFORMATIONS

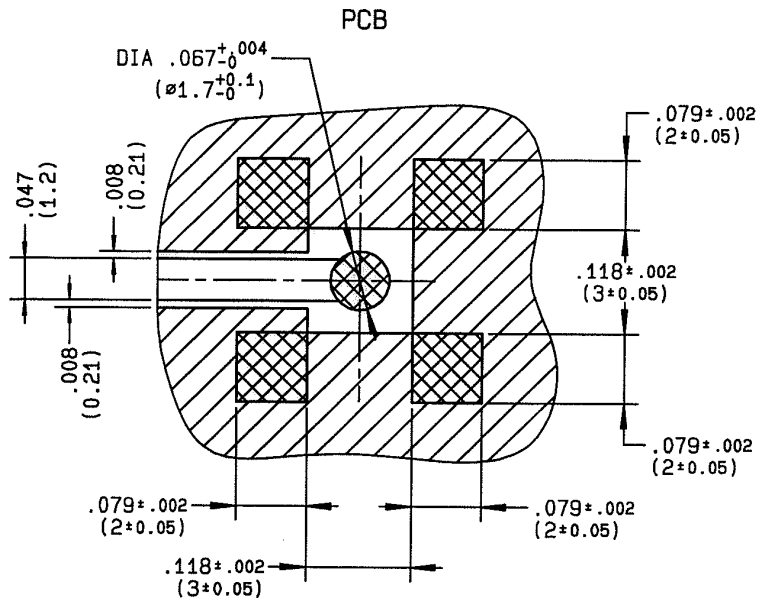

ASPIRATION PORT

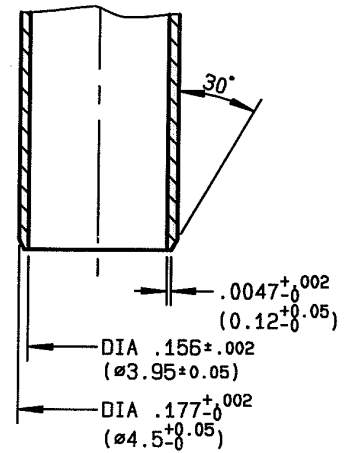

COPLANAR LINE

Pattern and signal are on the same side

Thickness of PCB : .063 (1.6 mm)

The material of PCB is the epoxy resin of glass fabrics bacs. (Er = 4.8)

The solder resist should be printed except for the land pattern on the PCB.



Pattern



Land for solder paste

SHADOW OF 'SMA B' RECEPTACLE FOR VIDEO CAMERA

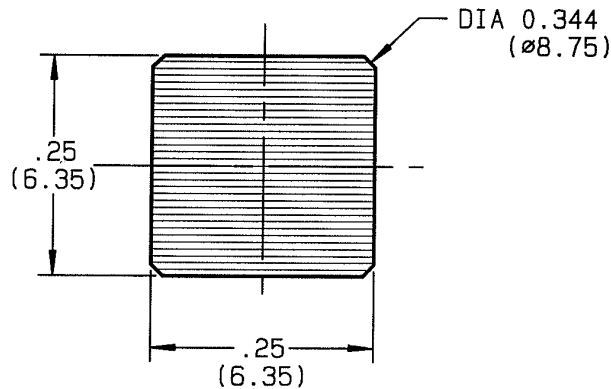

Issue : 1138 B

In the effort to improve our products, we reserve the right to make changes judged to be necessary.

