

SMA SWITCH EDGE CARD SMT RIGHT TYPE

**R124.422.001**

PACKAGING IN REEL 110

Series : SMA-COM

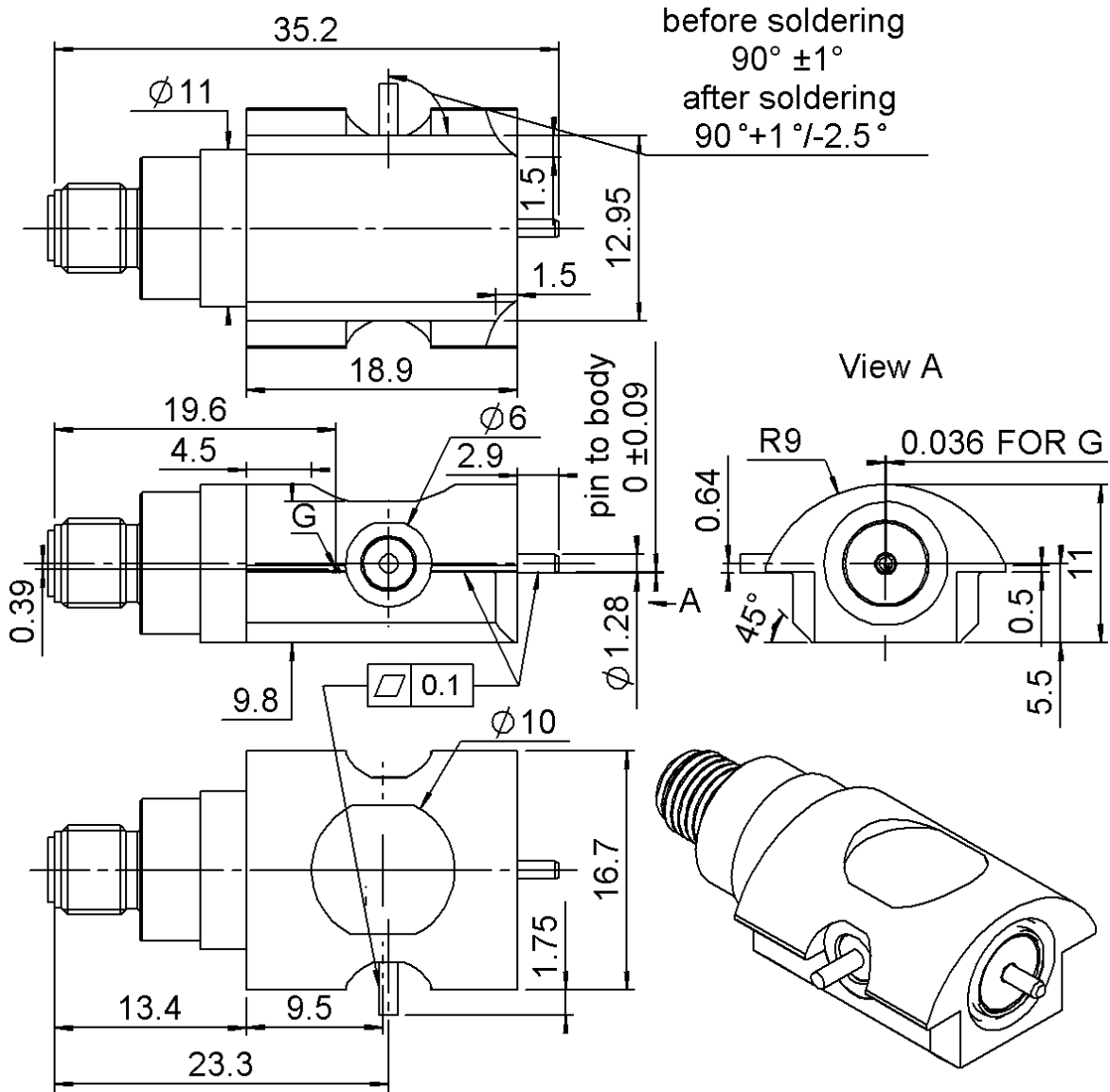

All dimensions are in mm.

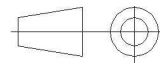

COMPONENTS	MATERIALS	PLATING (µm)
BODY	BRASS	NPGR, BBR 2
CENTER CONTACT	BERYLIUM COPPER	NPGR
OUTER CONTACT	BRASS	BBR 2
INSULATOR	PEEK	
GASKET		
OTHERS PARTS	BRASS	NPGR
-	-	-
-	-	-

Issue : 1030 A

In the effort to improve our products, we reserve the right to make changes judged to be necessary.



**SMA SWITCH EDGE CARD SMT RIGHT TYPE**

**R124.422.001**

**PACKAGING IN REEL 110**

Series : SMA-COM

**PACKAGING**

**SPECIFICATION**

Standard	Unit	Other
<b>110</b>	<b>'W' option</b>	<b>Contact us</b>

**ELECTRICAL CHARACTERISTICS**

**ENVIRONMENTAL**

Impedance	<b>50</b>	$\Omega$
Frequency	<b>DC-3</b>	GHz
VSWR	<b>1.1 + 0.1000</b>	x F(GHz) Maxi
Isolation at DC to 1 GHz	<b>-47</b>	dB Typical
Isolation at 1 to 2 GHz	<b>-43</b>	dB Typical
Isolation at 2 to 3 GHz	<b>-40</b>	dB Typical
Insertion loss at DC to 1 GHz	<b>0.1</b>	dB Maxi
Insertion loss at 1 to 2 GHz	<b>0.15</b>	dB Maxi
Insertion loss at 2 to 3 GHz	<b>0.2</b>	dB Maxi
RF leakage	- ( <b>NA</b> )	- F(GHz)) dB Maxi
Voltage rating	<b>300</b>	Veff Maxi
Dielectric withstanding voltage	<b>500</b>	Veff mini
Insulation resistance	<b>5000</b>	M $\Omega$ mini
Power withstanding	<b>80</b>	W at 0.9 GHz
	<b>50</b>	W at 1.8 GHz

Operating temperature	<b>-40/+85</b>	$^{\circ}$ C
Hermetic seal	<b>NA</b>	Atm.cm3/s
Panel leakage	<b>NA</b>	

**OTHER CHARACTERISTICS**

Assembly instruction **NA**

Others :

Action Mating force  
20N MAX  
15N min

(1)Do not apply force on the center contact before mounting the switch on PCB

**MECHANICAL CHARACTERISTICS**

Center contact retention		
Axial force – Mating end	<b>NA</b>	N mini
Axial force – Opposite end	<b>NA</b>	N mini
Torque	<b>NA</b>	N.cm mini
Axial force side pin	<b>(1)</b>	
Recommended torque		
Mating	<b>NA</b>	N.cm
Panel nut	<b>NA</b>	N.cm
Mating life	<b>100</b>	Cycles mini
Weight	<b>22.0700</b>	g

Issue : 1030 A

In the effort to improve our products, we reserve the right to make changes judged to be necessary.



**SMA SWITCH EDGE CARD SMT RIGHT TYPE**  
**PACKAGING IN REEL 110**

**R124.422.001**

Series : SMA-COM

**SOLDER PROCEDURE**

1. Deposit solder paste ‘Sn Ag4 Cu0.5’ on mounting zone by screen printing application. We recommend a low residue flux.  
 We advise a thickness of 150 microm ( 5.850 microinch ). Verify that the edges of the zone are clean.
2. Placement of the receptacle on the mounting zone with an automatic machine of ‘pick and place’ type. A video camera is recommended for positioning of the component . Adhesive agents must not be used on the receptacle.
3. This process of soldering has been tested with convection oven .Below please find ,the typical profile to use.
4. The cleaning of printed circuit boards is not obliged .
5. Verification of solder joints and position of the component by visual inspection.

**NOTE** : The receptacle and the plug must not be mated before completion of this procedure

**TEMPERATURE PROFILE**

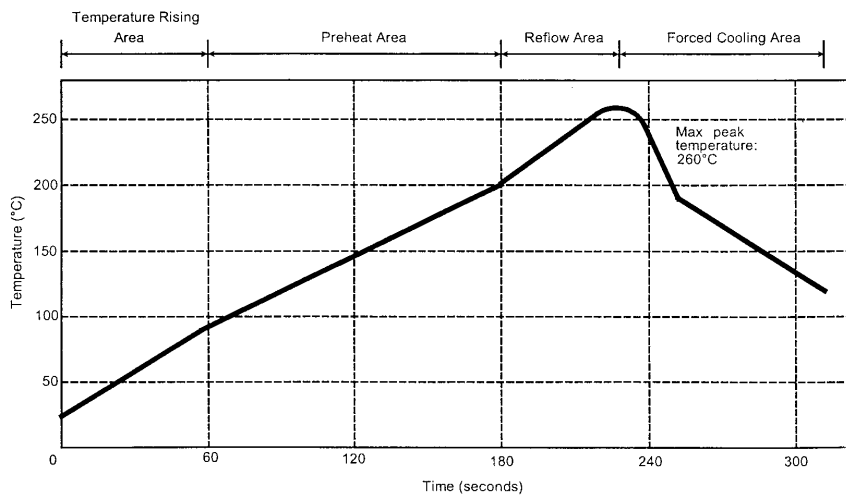

Parameter	Value	Unit
Temperature rising Area	1 - 4	°C/sec
Max Peak Temperature	260	°C
Max dwell time @260°C	10	sec
Min dwell time @235°C	20	sec
Max dwell time @235°C	60	sec
Temperature drop in cooling Area	-1 to - 4	°C/sec
Max dwell time above 100°C	420	sec

Issue : 1030 A

In the effort to improve our products, we reserve the right to make changes judged to be necessary.



**SMA SWITCH EDGE CARD SMT RIGHT TYPE**

**R124.422.001**

**PACKAGING IN REEL 110**

Series : SMA-COM

**PCB for SMA switch**

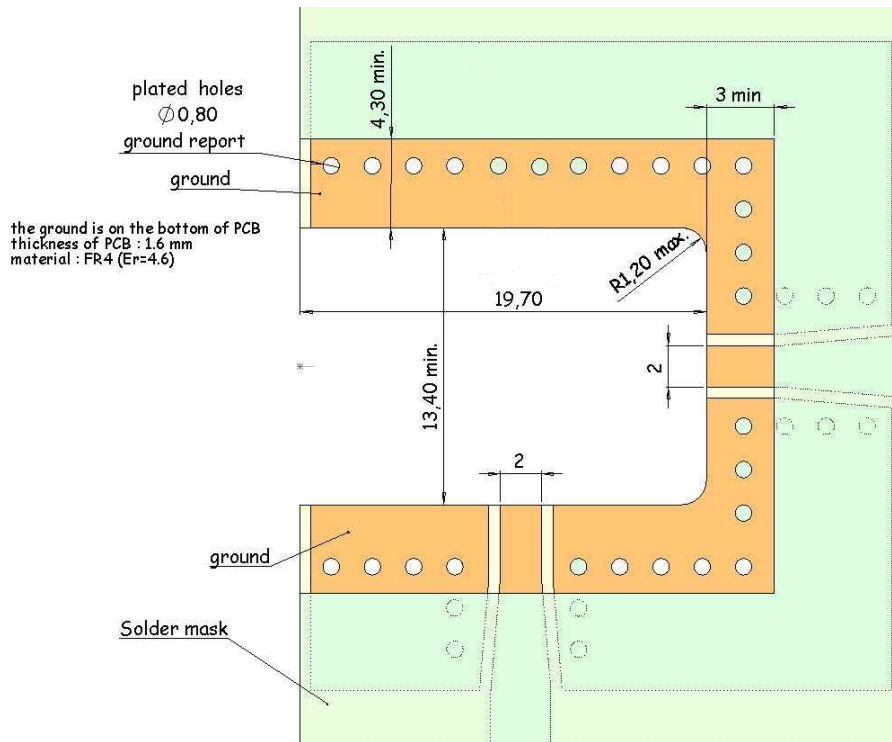

**Shadow of SMA switch for video camera**

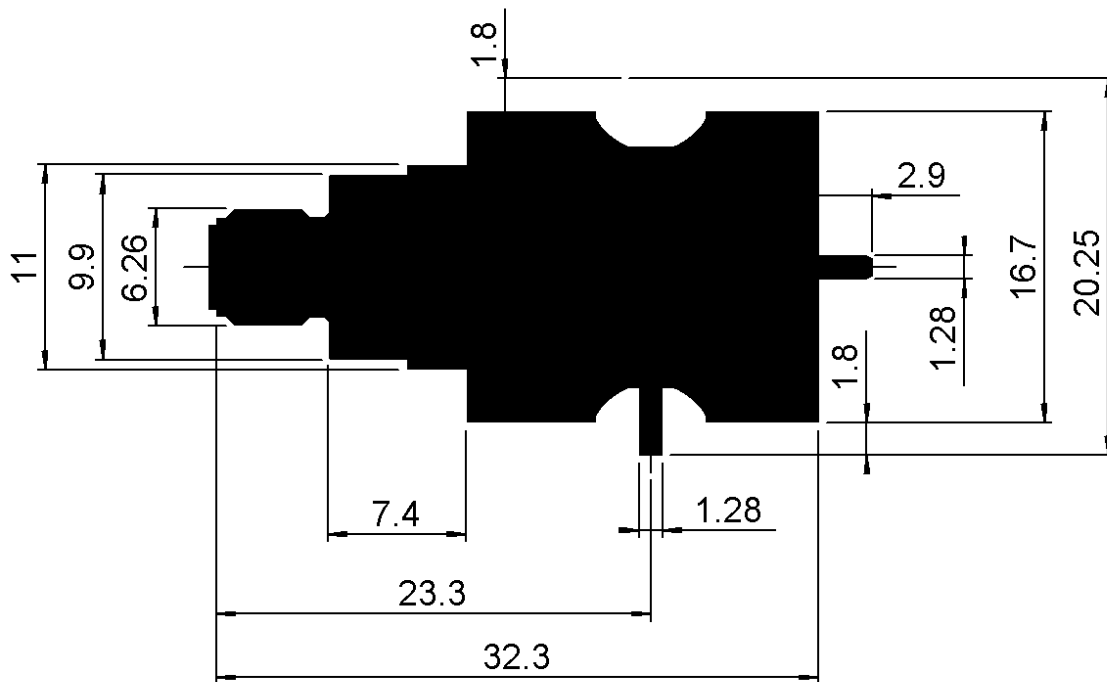

Issue : 1030 A

In the effort to improve our products, we reserve the right to make changes judged to be necessary.



**SMA SWITCH EDGE CARD SMT RIGHT TYPE**  
**PACKAGING IN REEL 110**

**R124.422.001**

Series : SMA-COM

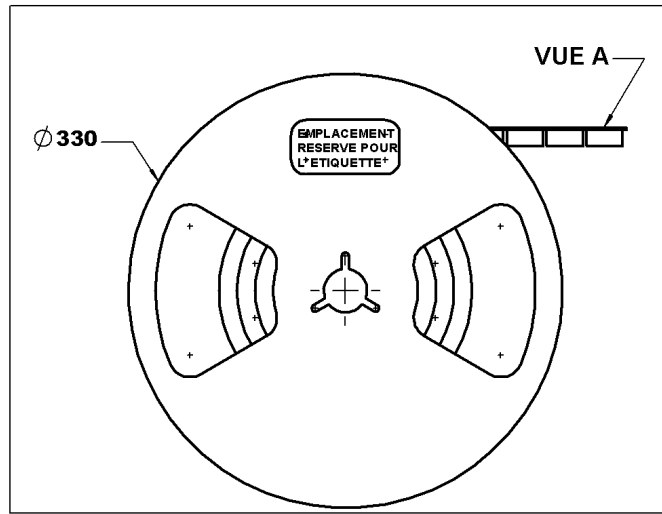

bobine Ech :0.7

TAPE FEED DIRECTION

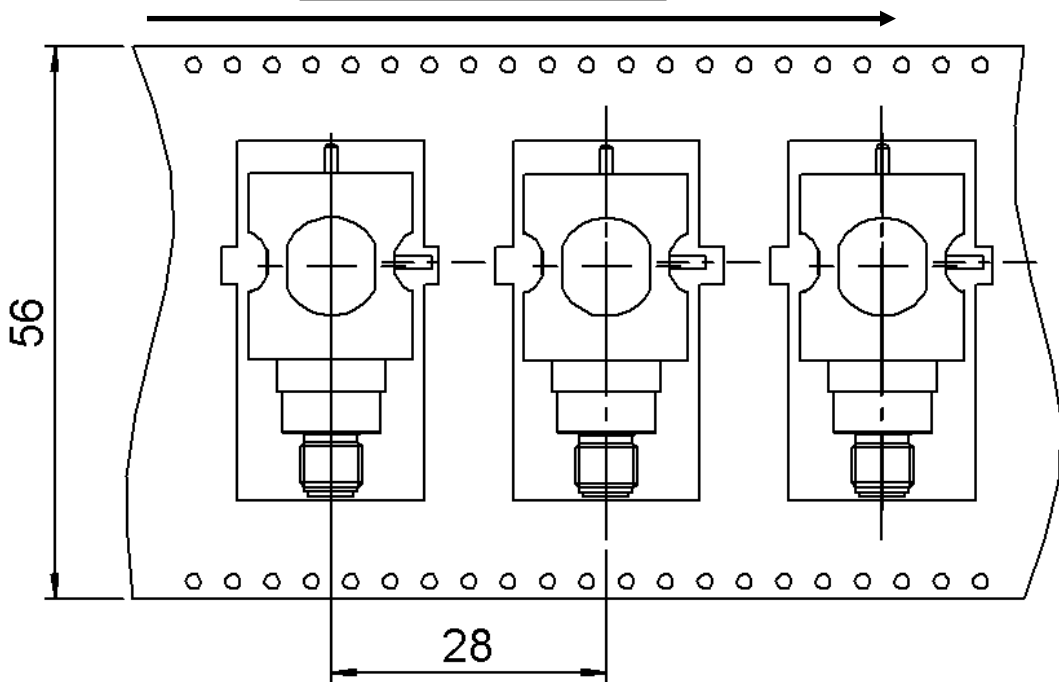

**VUE A**

Issue : 1030 A

In the effort to improve our products, we reserve the right to make changes judged to be necessary.

