

**RIGHT ANGLE PLUG CRIMP TYPE  
CABLE 2.6/50 S**

**R124.172.123**  
**SERIES SMA-COM**

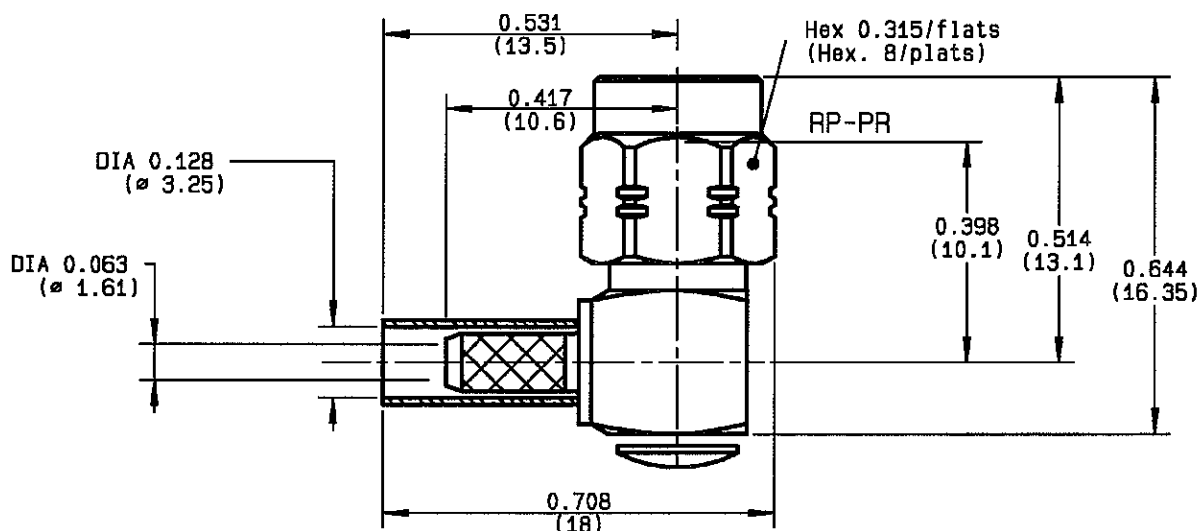

NOMINAL IMPEDANCE	<b>50</b> Ω	CABLES : <b>KX 22A</b>
FREQUENCY RANGE	<b>0-12.4</b> GHz	<b>RS 188</b>
TEMPERATURE RATING	<b>-65/+165</b> °C	<b>RS 31B</b>
V.S.W.R	<b>1.15 + .03 x F(GHz)Maxi</b>	
RF INSERTION LOSS	<b>0.05</b> √F(GHz) dB Maxi	
VOLTAGE RATING	<b>250</b> Veff Maxi	
DIELECTRIC WITHSTANDING VOLTAGE	<b>750</b> Veff Mini	
INSULATION RESISTANCE	<b>5000</b> MΩMini	OTHERS CHARACTERISTICS
HERMETIC SEAL	<b>NA</b> Atm.cm <sup>3</sup> /s	CABLE RETENTION
LEAKAGE (pressurized only)	<b>NA</b>	<b>90</b> N Mini
MECHANICAL DURABILITY	<b>100</b> Cycles	CENTER CONTACT RETENTION
WEIGHT	<b>4.75</b> gr	Axial force - mating end
SPECIFICATION		<b>27</b> N Mini
		Axial force - opposite end
		<b>27</b> N Mini
		Torque
		<b>NA</b> cm.N Mini
		RECOMMENDED TORQUES
		Mating
		<b>60</b> cm.N
		Panel nut
		<b>NA</b> cm.N
		Clamp nut
		<b>NA</b> cm.N

CONNECTOR PARTS:	MATERIALS	FINISH	(all values are given in micrometers)
BODY	BRASS	GOLD 0.2 OVER NICKEL 2	
OUTER CONTACT			
CENTER CONTACT	BRASS	GOLD 1.3 OVER COPPER 2.5	
INSULATOR	PTFE	-	
GASKET		-	
OTHERS PIECES	BRASS	GOLD 0.2 OVER NICKEL 2	

ISSUE  
**0708E**

CREATION DATE  
**30/06/1993**

FILE PART-NUMBER  
**EPC 97-03**



**RADIALL®**

TRIGUES E.

The information given here is subject to change without notice.  
Design changes may be in order to improve the product.

*Connect to the future*



**R124.172.123**  
 ISSUE 0708E SERIES SMA-COM

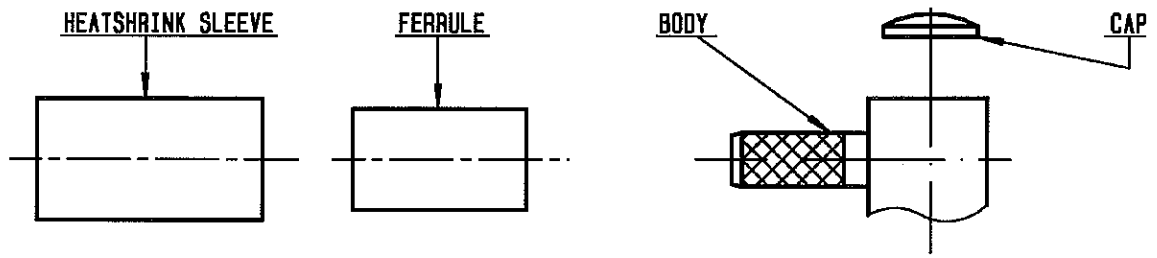

① Slide heatshrink sleeve (R280.637.020 - Option) and the ferrule onto cable .  
 Strip the cable .  
 -  
 -

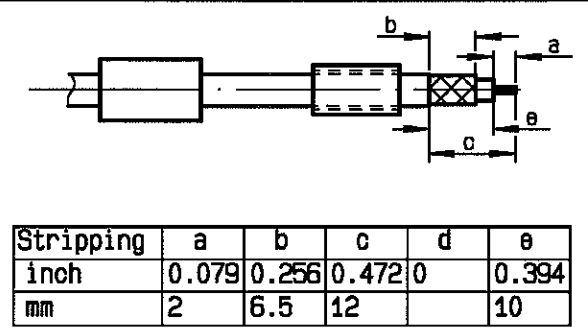

② Fan the braid .  
 Push connector body under the braid .  
 Slide ferrule over braid ( in direction F )  
 -  
 -

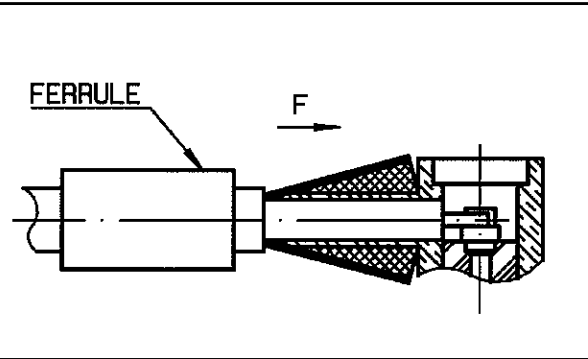

③ Crimp the ferrule with crimping tool R282 211 000 ( Hex. : 0.128 ) or crimping tool R 282 293 000 ( M22520/5-01 ) + dies R 282 235 003 ( M22520/5-03 )  
 Solder inner conductor .

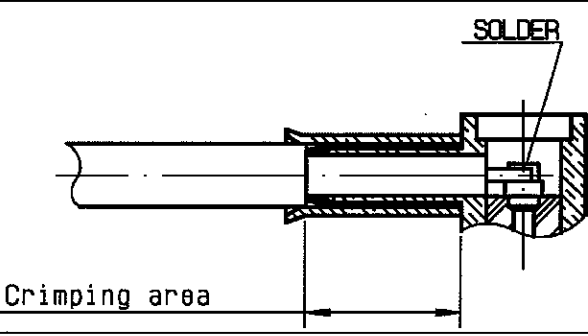

④ Place the cap into body .  
 Press cap flush or slightly below surface of body assembly .  
 Slide sleeve over ferrule and heatshrink in place (Option) .  
 -  
 -  
 -

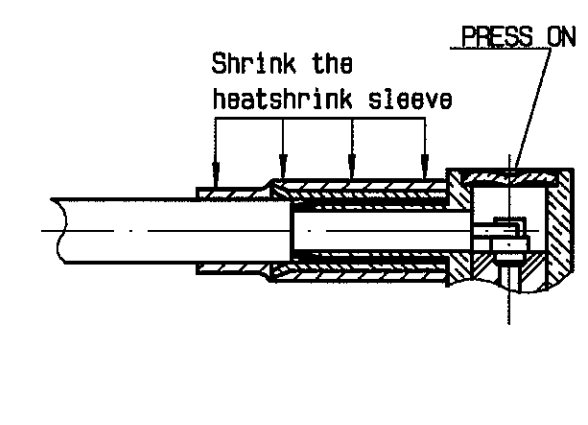

TRIGUES E.