

STRAIGHT FEMALE RECEPTACLE FOR PCB

R113.424.010

SMT TYPE - REEL OF 100

Series : **MCX**

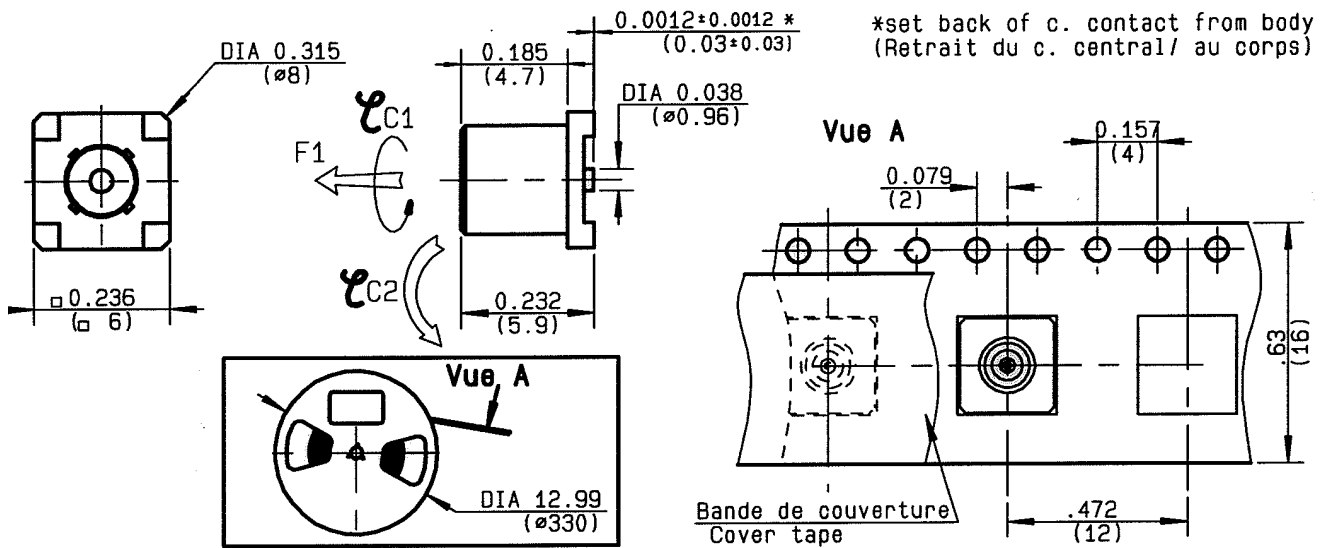

All dimensions are in mm.

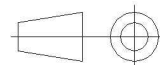

COMPONENTS	MATERIALS	PLATINGS (µm)
BODY	BRASS	GOLD 0.2 OVER NICKEL 2
CENTER CONTACT	BERYLLIUM COPPER	GOLD 0.5 OVER NICKEL 2
OUTER CONTACT	-	-
INSULATOR	PTFE	-
GASKET	-	-
OTHERS PARTS	-	-
-	-	-
-	-	-

Issue : 0422 D

In the effort to improve our products, we reserve the right to make changes judged to be necessary.



STRAIGHT FEMALE RECEPTACLE FOR PCB

R113.424.010

SMT TYPE - REEL OF 100

Series : **MCX**

PACKAGING

SPECIFICATION

Standard	Unit	Other
100	'W' option	Contact us

ELECTRICAL CHARACTERISTICS

ENVIRONMENTAL

Impedance		50 Ω
Frequency		0-6 GHz
VSWR	1.05 +	0.050 x F(GHz) Maxi
Insertion loss		0.03 √F(GHz) dB Maxi
RF leakage	- (NA - F(GHz)) dB Maxi
Voltage rating		335 Veff Maxi
Dielectric withstanding voltage		1000 Veff mini
Insulation resistance		1000 MΩ mini

Operating temperature	-55/+155 ° C
Hermetic seal	NA Atm.cm3/s
Panel leakage	NA

OTHERS CHARACTERISTICS

Assembly instruction

Others :

FORCE F1:90N-TORQUES C1:45Ncm-C2:80Ncm

MECHANICAL CHARACTERISTICS

Center contact retention		
Axial force – Mating end		10 N mini
Axial force – Opposite end		10 N mini
Torque		NA N.cm mini
Recommended torque		
Mating		NA N.cm
Panel nut		NA N.cm
Mating life		500 Cycles mini
Weight		0.600 g

Issue : 0422 D

In the effort to improve our products, we reserve the right to make changes judged to be necessary.



RADIALL®

STRAIGHT FEMALE RECEPTACLE FOR PCB

R113.424.010

SMT TYPE - REEL OF 100

Series : MCX

SOLDER PROCEDURE

1. Deposit solder paste 'Sn Ag4 Cu0.5' on mounting zone by screen printing application. We recommend a low residue flux. We advise a thickness of 150 microms mini. (.006 inch mini). Verify that the edges of the zone are clean.
2. Placement of the receptacle on the mounting zone with an automatic machine of 'pick and place' type. Aspiration port (see page 4) centered into body and push against it. A video camera is recommended for positioning of the component. Adhesive agents must not be used on the receptacle.
3. Soldering by infra-red reflow. Below please find the typical profile to use.
4. Cleaning of printed circuit boards.
5. Verification of solder joints and position of the component by visual inspection.

TEMPERATURE PROFILE

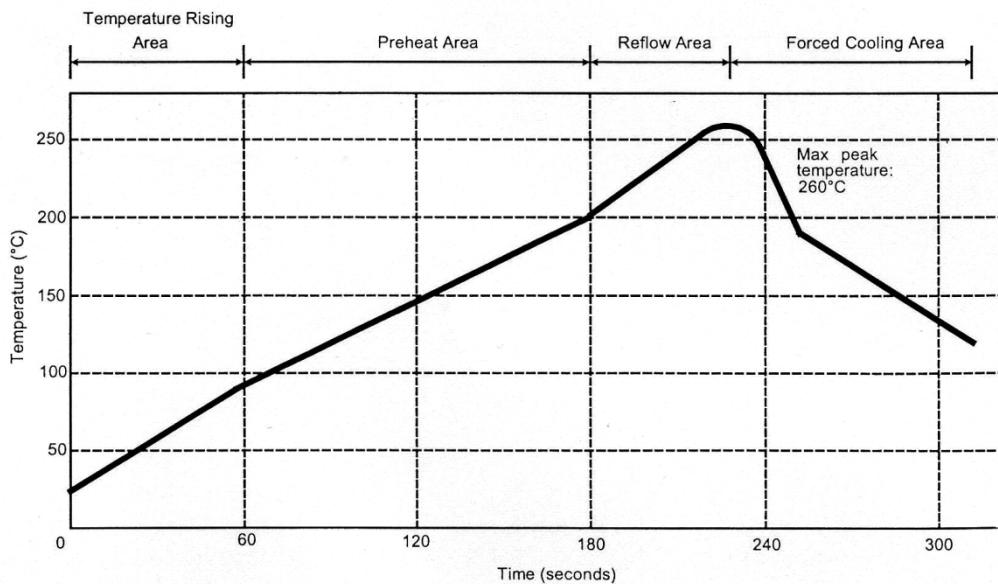

Parameter	Value	Unit
Temperature rising Area	1 - 4	°C/sec
Max Peak Temperature	260	°C
Max dwell time @260°C	10	sec
Min dwell time @235°C	20	sec
Max dwell time @235°C	60	sec
Temperature drop in cooling Area	-1 to - 4	°C/sec
Max dwell time above 100°C	420	sec

Issue : 0422 D

In the effort to improve our products, we reserve the right to make changes judged to be necessary.



STRAIGHT FEMALE RECEPTACLE FOR PCB

R113.424.010

SMT TYPE - REEL OF 100

Series : MCX

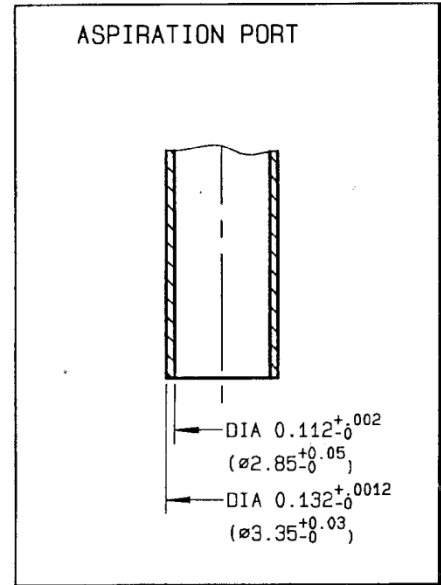
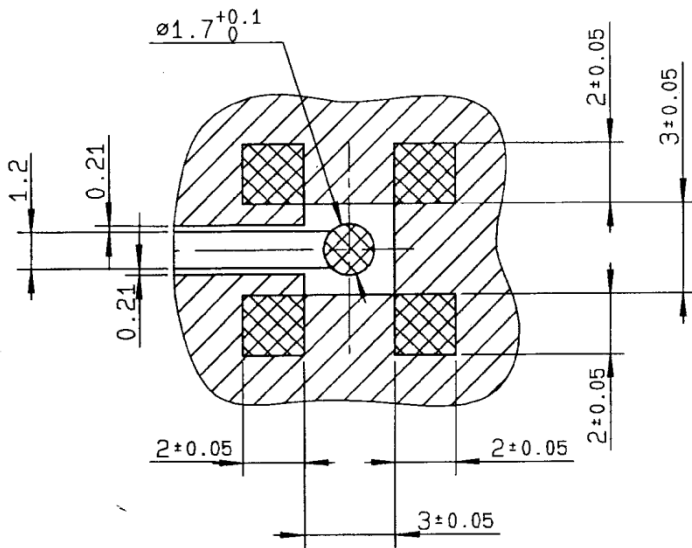

COPLANAR LINE

Pattern and signal are on the same side
 Thickness of PCB : .063 (1.6 mm)
 The material of PCB is the epoxy resin
 of glass fabrics bacs. (Er = 4.8)
 The solder resist should be printed
 except for the land pattern on the PCB.



Pattern



Land for solder paste

**SHADOW OF MCX RECEPTACLE
 FOR VIDEO CAMERA**

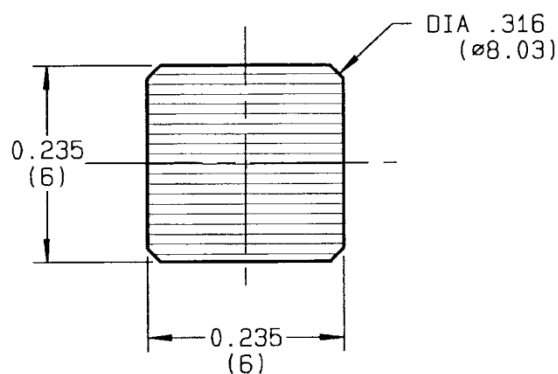

Issue : 0422 D

In the effort to improve our products, we reserve the right to make changes judged to be necessary.



RADIALL®