

REVISIONS			
REV	DESCRIPTION	DATE	APPROVED
A	INITIAL RELEASE	05/14/08	A.D.M.

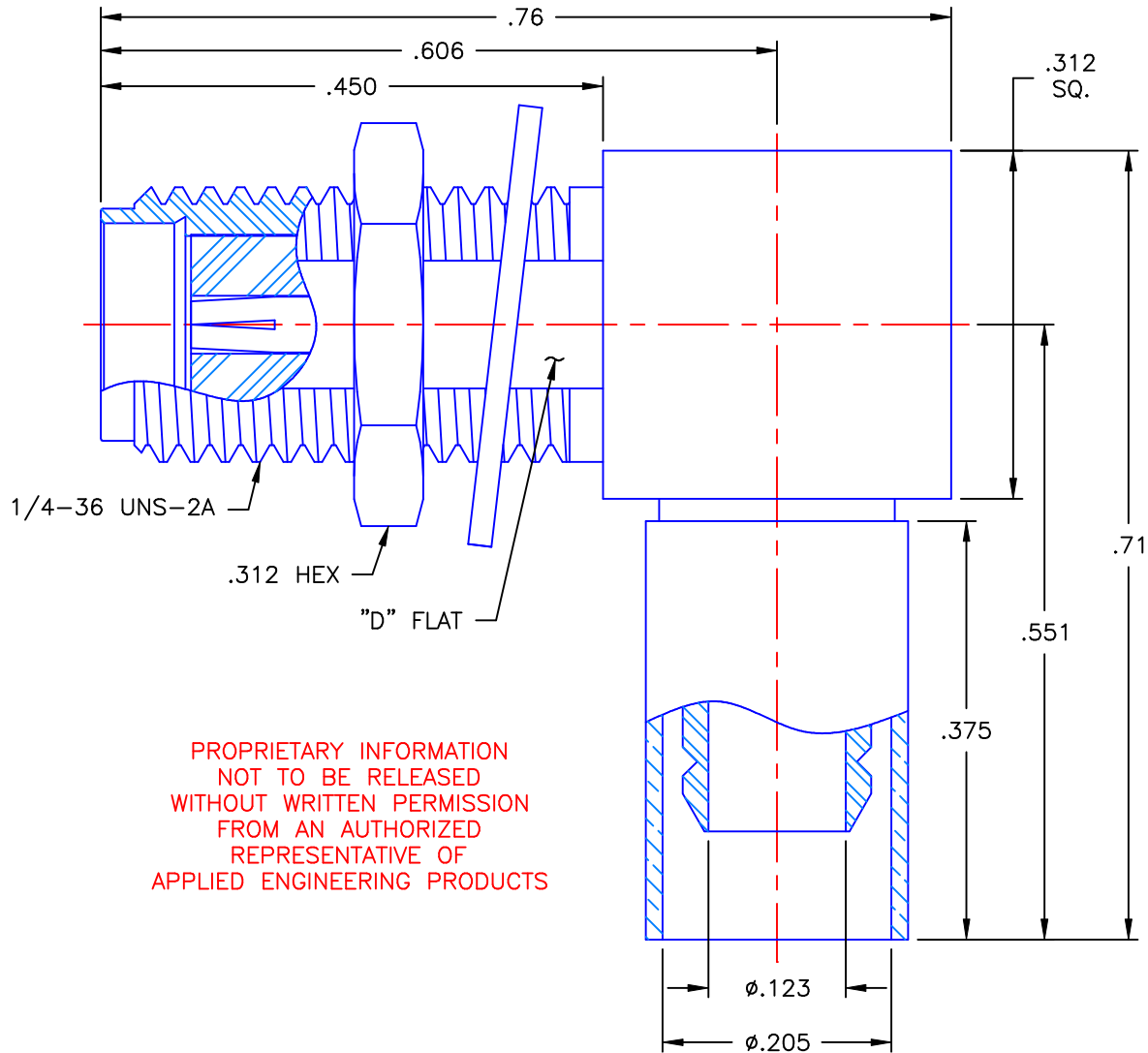

PROPRIETARY INFORMATION  
 NOT TO BE RELEASED  
 WITHOUT WRITTEN PERMISSION  
 FROM AN AUTHORIZED  
 REPRESENTATIVE OF  
 APPLIED ENGINEERING PRODUCTS



**NOTES:**

**MATERIALS:**

- BODIES & NUT = STAINLESS STEEL PER ASTM A582, ALLOY 303, CONDITION "A".
- INSULATORS = VIRGIN WHITE TEFLON PER ASTM D1710, GRADE 1, TYPE I, CLASS "B".
- CONTACT = BERYLLIUM COPPER PER ASTM B196, ALLOY C17300, TEMPER TD04.
- LOCKWASHER = PHOSPHOR BRONZE PER ASTM B139, COPPER ALLOY C53400, TEMPER H04.
- CAP = BRASS PER ASTM B16, ALLOY C36000, TEMPER H02.

**FINISHES:**

- BODIES & NUT = PASSIVATE PER QQ-P-35, TYPE VI.
- CONTACT = GOLD PLATE PER MIL-G-45204, TYPE II, CLASS 1, GRADE C, OVER .00010 TO .00020 STRESS FREE SULFAMATE NICKEL PER QQ-N-290.
- LOCKWASHER & CAP = NICKEL PLATE PER QQ-N-290, CLASS 1, GRADE G, EXCEPT .0001 TO .0002 THICK OVER .00005 TO .0001 THICK COPPER PER MIL-C-14550.

UNLESS OTHERWISE SPECIFIED DIMENSIONS ARE IN INCHES TOLERANCES ON	DWN: A.D.M.	DATE 05/14/08	 <b>APPLIED ENGINEERING PRODUCTS</b> 104 John W. Murphy Dr. New Haven, CT 06513
	CHKD: D.N.	DATE 05/14/08	
DECIMAL	ANGLE	APVD: J.M.	DATE 05/14/08
		SMA RIGHT ANGLE JACK BULKHEAD MOUNT CRIMP TYPE FOR RG-58 & SIMILAR CABLES	
REFERENCE:	MATERIALS & FINISHES:	SIZE A	FSCM NO. 19505
ORIGINATOR: A.D.M. DATE: 05/14/08	SEE NOTES	DWG. NO. 9613-9523-006	REV A
		SCALE 6:1	THIRD ANGLE PROJECTION 
		SHEET 1 OF 1	

9613-9523-006