

PROPRIETARY INFORMATION
 NOT TO BE RELEASED
 WITHOUT WRITTEN PERMISSION
 FROM AN AUTHORIZED
 REPRESENTATIVE OF
 APPLIED ENGINEERING PRODUCTS

REVISIONS			
REV	DESCRIPTION	DATE	APPROVED
A	INITIAL RELEASE	12/03/07	D.N.

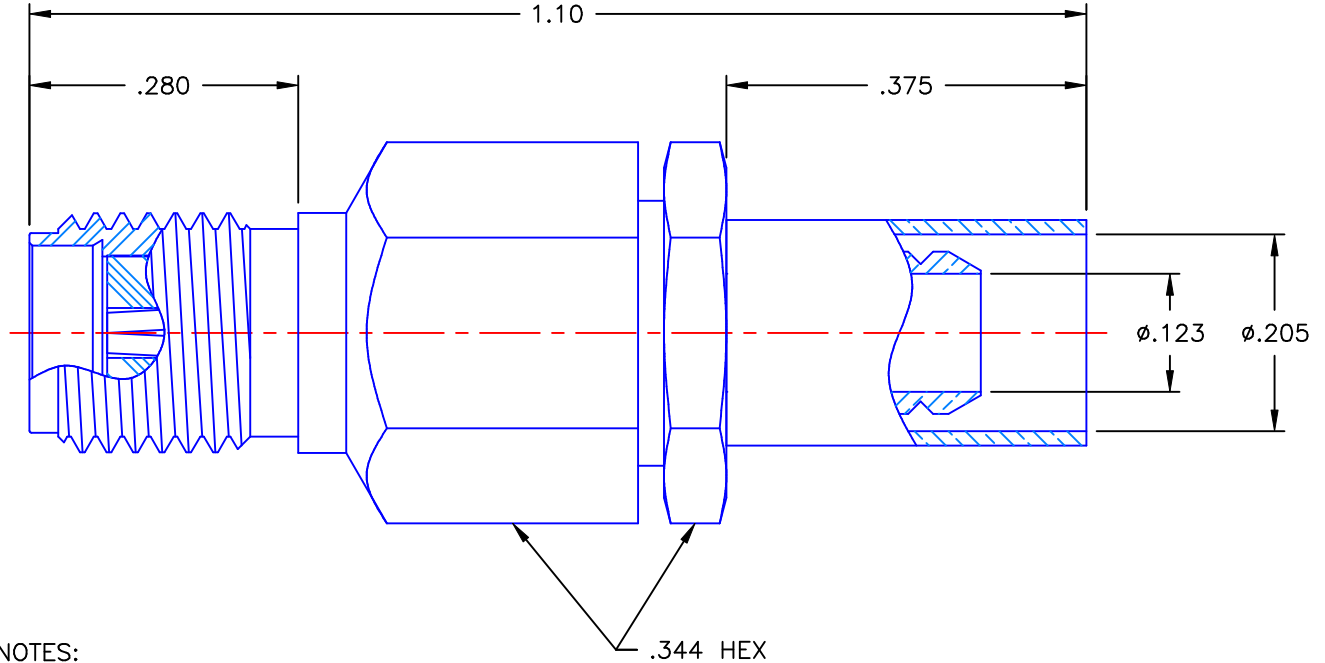



NOTES:

MATERIALS:

1. BODY = STAINLESS STEEL PER ASTM A582, ALLOY 303, CONDITION "A".
2. INSULATORS = VIRGIN WHITE TEFLON PER ASTM D1710, GRADE 1, TYPE I, CLASS "B".
3. CONTACT = BERYLLIUM COPPER PER ASTM B196, ALLOY C17300, TEMPER TD04.
4. CRIMP NUT = BRASS PER ASTM B16, ALLOY C36000, TEMPER H02.
5. CRIMP SLEEVE = SEAMLESS LOWLEAD BRASS TUBE, ALLOY 330, SOFT ANNEAL TEMPER, .025/.060 GRAIN SIZE OR SEAMLESS COPPER TUBE PER ASTM B75, TYPE C12000, TEMPER: LIGHT ANNEAL O50 EXCEPT YIELD STRENGTH.
6. SHRINK SLEEVE = THEROFIT SCL, BLACK (NOT SHOWN).

FINISHES:

1. BODY = PASSIVATE PER QQ-P-35, TYPE VI.
2. CONTACT = GOLD PLATE PER MIL-G-45204, TYPE II, CLASS 1, GRADE C, OVER .00010 TO .00020 STRESS FREE SULFAMATE NICKEL PER QQ-N-290.
3. CRIMP SLEEVE & NUT = NICKEL PLATE PER QQ-N-290, CLASS 1, GRADE G, EXCEPT .0001 TO .0002 THICK OVER .00005 TO .0001 THICK COPPER PER MIL-C-14550.

UNLESS OTHERWISE SPECIFIED DIMENSIONS ARE IN INCHES TOLERANCES ON	DWN: D.N.	DATE 12/03/07	 APPLIED ENGINEERING PRODUCTS 104 John W. Murphy Dr. New Haven, CT 06513	
	DECIMAL	ANGLE		CHKD: A.D.M.
REFERENCE:	MATERIALS & FINISHES: SEE NOTES			SMA STRAIGHT JACK CRIMP TYPE FOR RG-58 & SIMILAR CABLES
ORIGINATOR: D.N. DATE: 12/03/07	SIZE A	FSCM NO. 19505	DWG NO. 9102-9573-006	REV A
SCALE 5:1		THIRD ANGLE PROJECTION 		SHEET 1 OF 1

9102-9573-006