

REVISIONS			
REV	DESCRIPTION	DATE	APPROVED
A	INITIAL RELEASE	11/10/10	A.D.M.

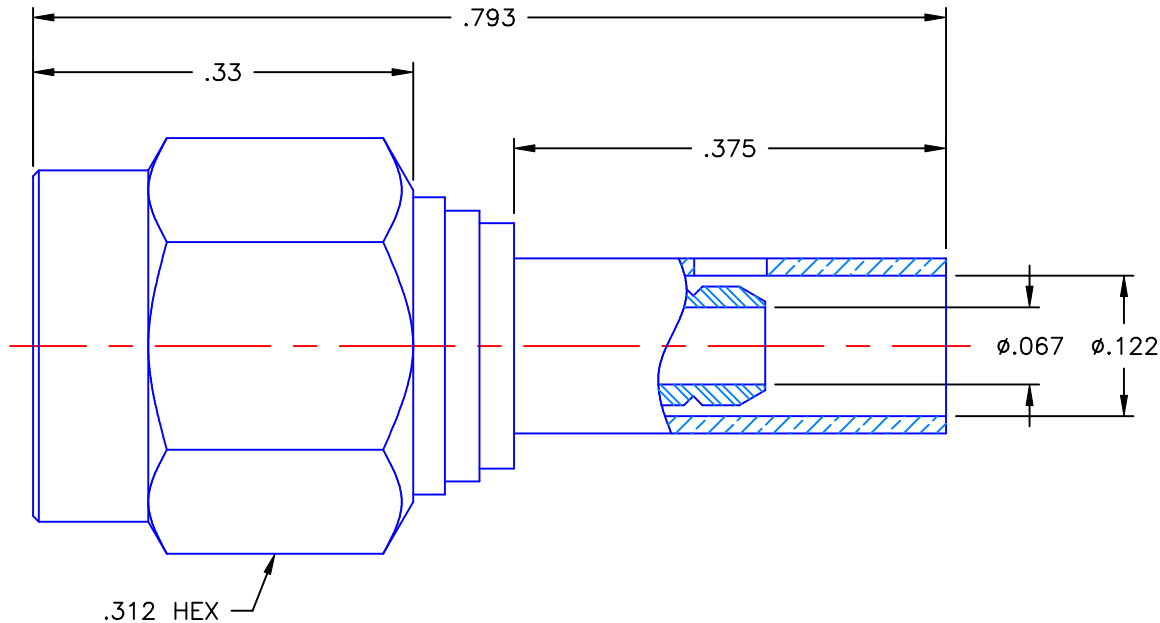

**NOTES:**

**MATERIALS:**

1. BODY & COUPLING NUT = STAINLESS STEEL PER ASTM A582, ALLOY 303, CONDITION "A".
2. INSULATORS = VIRGIN WHITE TEFLON PER ASTM D1710, GRADE 1, TYPE I, CLASS "B".
3. CONTACT & RETAINING RING = BERYLLIUM COPPER PER ASTM B196, ALLOY C17300, TEMPER TD04.
4. CRIMP SLEEVE = SEAMLESS LOWLEAD BRASS TUBE, ALLOY 330, SOFT ANNEAL TEMPER, .025/.060 GRAIN SIZE OR SEAMLESS COPPER TUBE PER ASTM B75, TYPE C12000, TEMPER: LIGHT ANNEAL O50 EXCEPT YIELD STRENGTH.
5. BUSHING = BRASS PER ASTM B16, ALLOY C36000, TEMPER H02.
6. GASKET = SILICONE RUBBER PER ZZ-R-765, CLASS 2B, GRADE 65-75.
7. SHRINK SLEEVE = THERMOFIT SCL (NOT SHOWN).

**FINISHES:**

1. BODY = GOLD PLATE PER MIL-G-45204, TYPE II, CLASS 0, GRADE C, OVER .000050 TO .00010 STRESS FREE NICKEL PER QQ-N-290.
2. CONTACT = GOLD PLATE PER MIL-G-45204, TYPE II, CLASS 1, GRADE C, OVER .00010 TO .00020 STRESS FREE SULFAMATE NICKEL PER QQ-N-290.
3. CRIMP SLEEVE & BUSHING = GOLD PLATE PER MIL-G-45204, TYPE II, CLASS 0, GRADE C, OVER .00010 TO .00020 COPPER STRIKE PER MIL-C-14550.
4. COUPLING NUT = PASSIVATE PER QQ-P-35, TYPE VI.

UNLESS OTHERWISE SPECIFIED DIMENSIONS ARE IN INCHES TOLERANCES ON	DWN:	DATE	
	A.D.M.	11/10/10	
	CHKD:	DATE	
DECIMAL	ANGLE	D.N.	11/10/10
		APVD:	DATE
		J.M.	11/10/10



Property of Radial  
This document cannot be reproduced or  
communicated to a third party without prior  
written permission of RADIAL.

**SMA STRAIGHT PLUG  
SOLDER/CRIMP TYPE  
FOR RG-178DS AND SIMILAR CABLES**

REFERENCE:	MATERIALS & FINISHES:
ORIGINATOR: A.D.M. DATE: 11/10/10	SEE NOTES

SIZE A	FSCM NO. 19505	DWG. NO. 9001-1033-005	REV A
SCALE 6:1	THIRD ANGLE PROJECTION		SHEET 1 OF 1

9001-1033-005