

REVISIONS			
REV.	DESCRIPTION	DATE	APPROVED
A	INITIAL RELEASE	03/31/09	A.D.M.

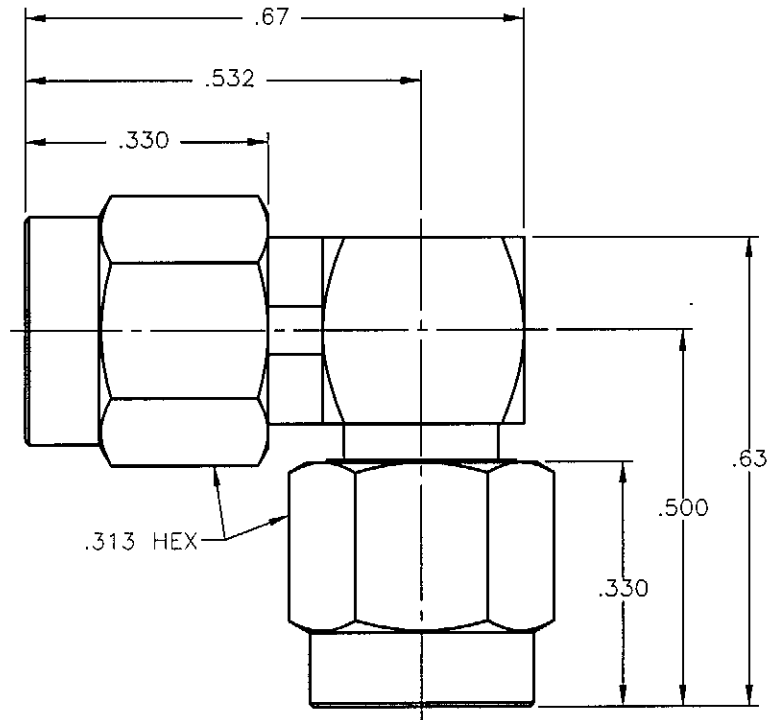

NOTES:

MATERIALS:

1. BODIES & COUPLING NUT = STAINLESS STEEL PER ASTM A582, ALLOY 303, CONDITION "A".
2. INSULATORS = VIRGIN WHITE TEFLON PER ASTM D1710, GRADE 1, TYPE I, CLASS "B".
3. CONTACTS & CAP = BRASS PER ASTM B16, ALLOY C36000, TEMPER H02.
4. RETAINING RING = BERYLLIUM COPPER PER ASTM B196, ALLOY C17300, TEMPER TD04.
5. GASKET = SILICONE RUBBER PER ZZ-R-765, CLASS 2B, GRADE 65-75.

FINISHES:

1. BODIES = GOLD PLATE PER MIL-G-45204, TYPE II, CLASS 0, GRADE C, OVER .000050 TO .00010 STRESS FREE NICKEL PER QQ-N-290.
2. COUPLING NUTS = PASSIVATE PER QQ-P-35, TYPE VI.
3. CONTACTS = GOLD PLATE PER MIL-G-45204, TYPE II, CLASS 1, GRADE C, OVER .00010 TO .00020 STRESS FREE SULFAMATE NICKEL PER QQ-N-290.
4. CAP = GOLD PLATE PER MIL-G-45204, TYPE II, CLASS 0, GRADE C, OVER .00010 TO .00020 COPPER STRIKE PER MIL-C-14550.

Property of Radiall Incorporated
 This document cannot be reproduced or
 communicated to a third party without prior
 written permission of RADIALL Incorporated.

UNLESS OTHERWISE SPECIFIED DIMENSIONS ARE IN INCHES TOLERANCES ON	DWN:	DATE	 APPLIED ENGINEERING PRODUCTS a RADIALL company 104 John W. Murphy Dr. New Haven, CT 06513
	A.D.M.	03/31/09	
DECIMAL	ANGLE	CHKD:	DATE
		D.N.	03/31/09
		APVD:	DATE
		J.M.	03/31/09
REFERENCE:		MATERIALS & FINISHES:	
ORIGINATED: A.D.M. DATE: 03/31/09		SEE NOTES	
SIZE	FSCM NO.	DWG NO.	REV
A	19505	5919-1503-001	A
SCALE 4:1		THIRD ANGLE PROJECTION	SHEET 1 OF 1

5919-1503-001