

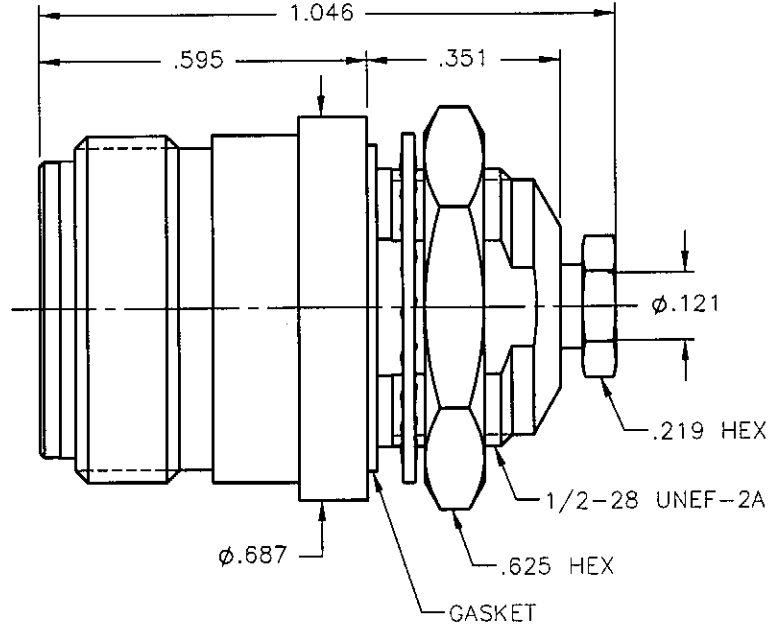

REVISIONS			
REV.	DESCRIPTION	DATE	APPROVED
A	INITIAL RELEASE	02/05/09	A.D.M.



NOTES:

MATERIALS:

1. INSULATORS = VIRGIN WHITE TEFLON PER ASTM D1710, GRADE 1, TYPE I, CLASS "B".
2. CONTACT = BERYLLIUM COPPER PER ASTM B196, ALLOY C17300, TEMPER TD04.
3. GASKET = SILICONE RUBBER 45-55 DUROMETER, DOW CORNING SILASTIC 250.
4. LOCKWASHER = PHOSPHOR BRONZE PER ASTM B139, COPPER ALLOY C53400, TEMPER H04.
5. ALL OTHER METAL PARTS = BRASS PER ASTM B16, ALLOY C36000, TEMPER H02.

FINISHES:

1. CONTACT = GOLD PLATE PER MIL-G-45204, TYPE II, CLASS 1, GRADE C, OVER .00010 TO .00020 STRESS FREE SULFAMATE NICKEL PER QQ-N-290.
2. ALL OTHER METAL PARTS = GOLD PLATE PER MIL-G-45204, TYPE II, CLASS 0, GRADE C, OVER .00010 TO .00020 COPPER STRIKE PER MIL-C-14550.

Property of Radiall Incorporated  
 This document cannot be reproduced or  
 communicated to a third party without prior  
 written permission of RADIALL Incorporated.

UNLESS OTHERWISE SPECIFIED DIMENSIONS ARE IN INCHES TOLERANCES ON	DWN: A.D.M.	DATE 02/05/09	<b>APPLIED ENGINEERING PRODUCTS</b> 104 John W. Murphy Dr. New Haven, CT 06513			
	CHKD:	DATE 02/05/09				
DECIMAL	ANGLE	D.N.	<b>TYPE "N" STRAIGHT JACK          BULKHEAD FRONT MOUNT SOLDER/CLAMP          TYPE FOR .085 S/R &amp; SIMILAR CABLES</b>			
		APVD: J.M.				DATE 02/05/09
REFERENCE:	MATERIALS & FINISHES: SEE NOTES		SIZE A	FSCM NO. 19505	DWG NO. 4502-1041-010	REV A
ORIGINATED: A.D.M. DATE: 02/05/09			SCALE 3:1	THIRD ANGLE PROJECTION		SHEET 1 OF 1

4502-1041-010