

PROPRIETARY INFORMATION
 NOT TO BE RELEASED
 WITHOUT WRITTEN PERMISSION
 FROM AN AUTHORIZED
 REPRESENTATIVE OF
 APPLIED ENGINEERING PRODUCTS

REVISIONS			
REV.	DESCRIPTION	DATE	APPROVED
A	INITIAL RELEASE	02/25/08	D.N.

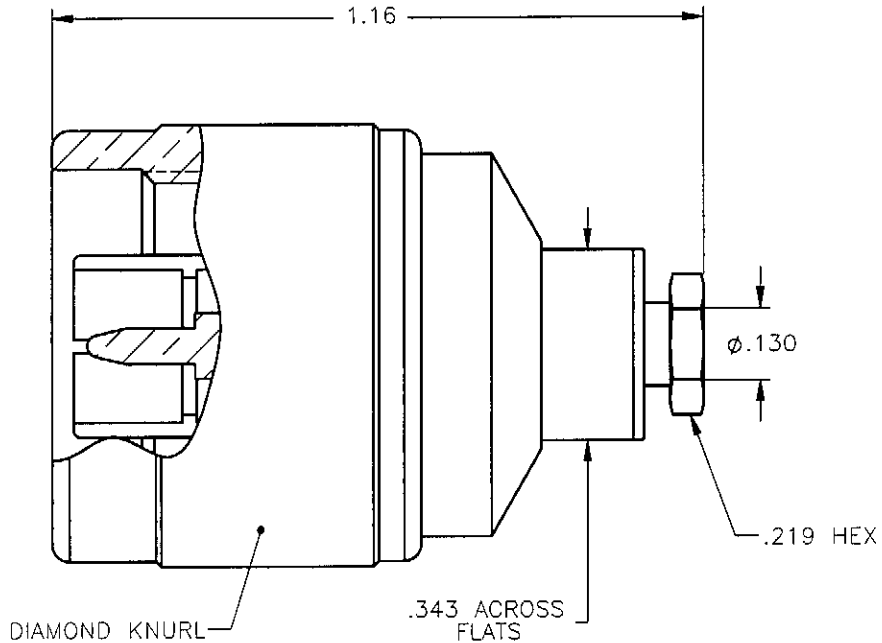

NOTES:

MATERIALS:

1. INSULATORS = VIRGIN WHITE TEFLON PER ASTM D1710, GRADE 1, TYPE I, CLASS "B".
2. RETAINING RING = PHOSPHOR BRONZE PER ASTM B139, COPPER ALLOY C53400, TEMPER H04.
3. GASKET = DOW CORNING SILASTIC 250 SILICONE RUBBER 45-55 DUROMETER.
4. ALL OTHER METAL PARTS = BRASS PER ASTM B16, ALLOY C36000, TEMPER H02.

FINISHES:

1. CONTACT = GOLD PLATE PER MIL-G-45204, TYPE II, CLASS 1, GRADE C, OVER .00010 TO .00020 STRESS FREE SULFAMATE NICKEL PER QQ-N-290.
2. ALL OTHER METAL PARTS = GOLD PLATE PER MIL-G-45204, TYPE II, CLASS 0, GRADE C, OVER .00010 TO .00020 COPPER STRIKE PER MIL-C-14550.

UNLESS OTHERWISE SPECIFIED DIMENSIONS ARE IN INCHES TOLERANCES ON		DWN:	DATE	 APPLIED ENGINEERING PRODUCTS 104 John W. Murphy Dr. New Haven, CT 06513 <i>a RADIALL company</i>			
		D.N.	02/25/08				
DECIMAL	ANGLE	CHKD:	DATE	TYPE "N" STRAIGHT PLUG CLAMP TYPE FOR RG-316DS AND SIMILAR CABLES			
		A.D.M.	02/25/08				
		APVD:	DATE				
		J.M.	02/25/08				
REFERENCE:		MATERIALS & FINISHES:		SIZE	FSCM NO.	DWG NO.	REV
ORIGINATED: D.N. DATE: 02/25/08		SEE NOTES		A	19505	4000-1051-019	A
				SCALE 3:1	THIRD ANGLE PROJECTION		SHEET 1 OF 1

4000-1051-019