



APPLIED ENGINEERING PRODUCTS

(203) 776-2813 FAX (203) 776-8294

www.aep.us

Assembly Instructions

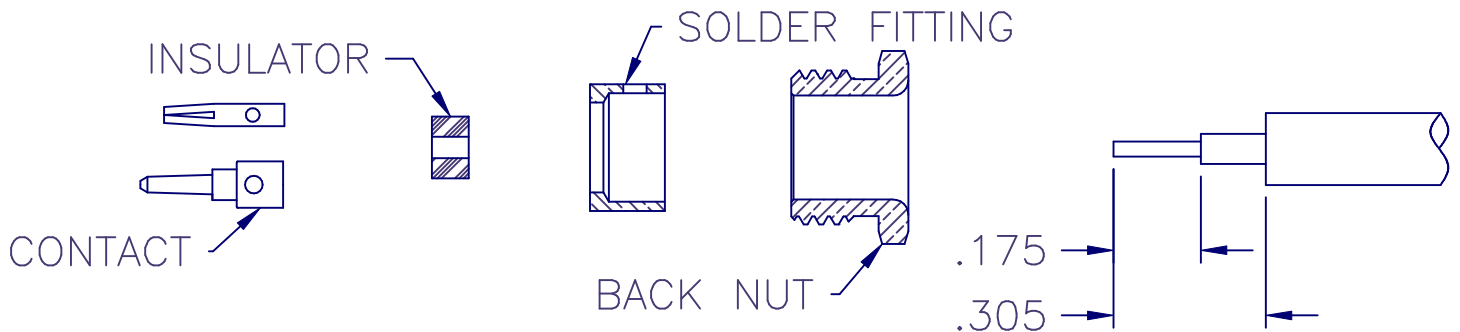

1. TRIM CABLE AS SHOWN.
2. SLIDE BACK NUT ONTO CABLE.

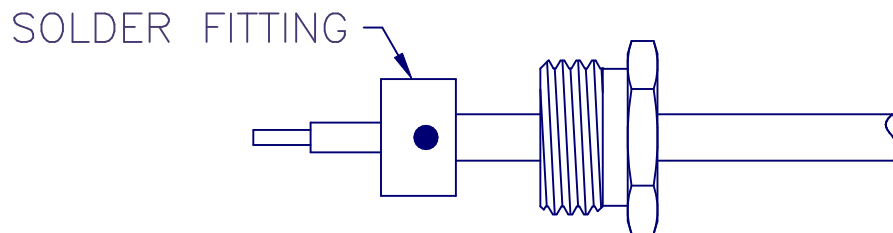

3. SLIDE SOLDER FITTING OVER CABLE DIELECTRIC UNTIL IT BOTTOMS ON THE CABLE JACKET.
4. SOLDER THE SOLDER FITTING TO CABLE JACKET. DO NOT DISTURB SOLDER JOINT UNTIL IT HAS COOLED.

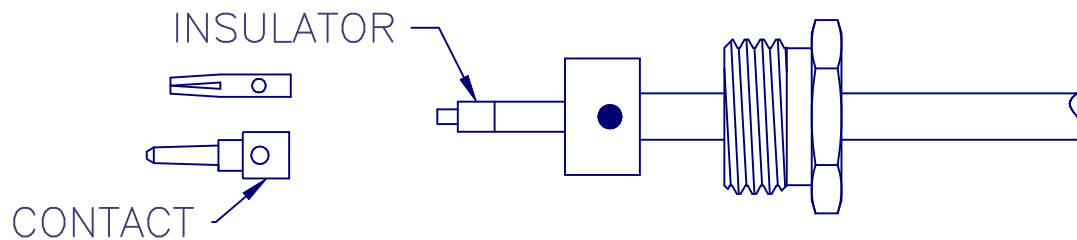

5. SLIDE INSULATOR OVER CENTER CONDUCTOR, SEATING FLUSH TO DIELECTRIC.
6. SOLDER CONTACT TO CENTER CONDUCTOR. CONTACT TO BE SEATED FLUSH AGAINST INSULATOR.
7. INSERT CABLE ASSEMBLY INTO CONNECTOR BODY AND TIGHTEN BACK NUT WITH A TORQUE OF 90-100 INCH OUNCES.

AIS-375-2B REV. -